

## **Sopwith Swallow Scale 1/33**

Copyright 2010 - F.Santandrea

**Not for commercial use**

From [Aviastar.org](http://Aviastar.org) site

Utilising an F.1 Camel fuselage mated with a parasol wing, the Swallow single-seat fighter monoplane was powered by a 110hp Le Rhone 9J nine-cylinder rotary engine and carried the standard armament of twin synchronised 7.7mm machine guns. Flown for the first time in September 1918, the Swallow was delivered to Martlesham Heath for official trials on 29 October 1918, remaining there until May 1919, the trials having been delayed by fuel system problems. The performance of the Swallow as revealed at Martlesham did not warrant further development, and the prototype was scrapped.



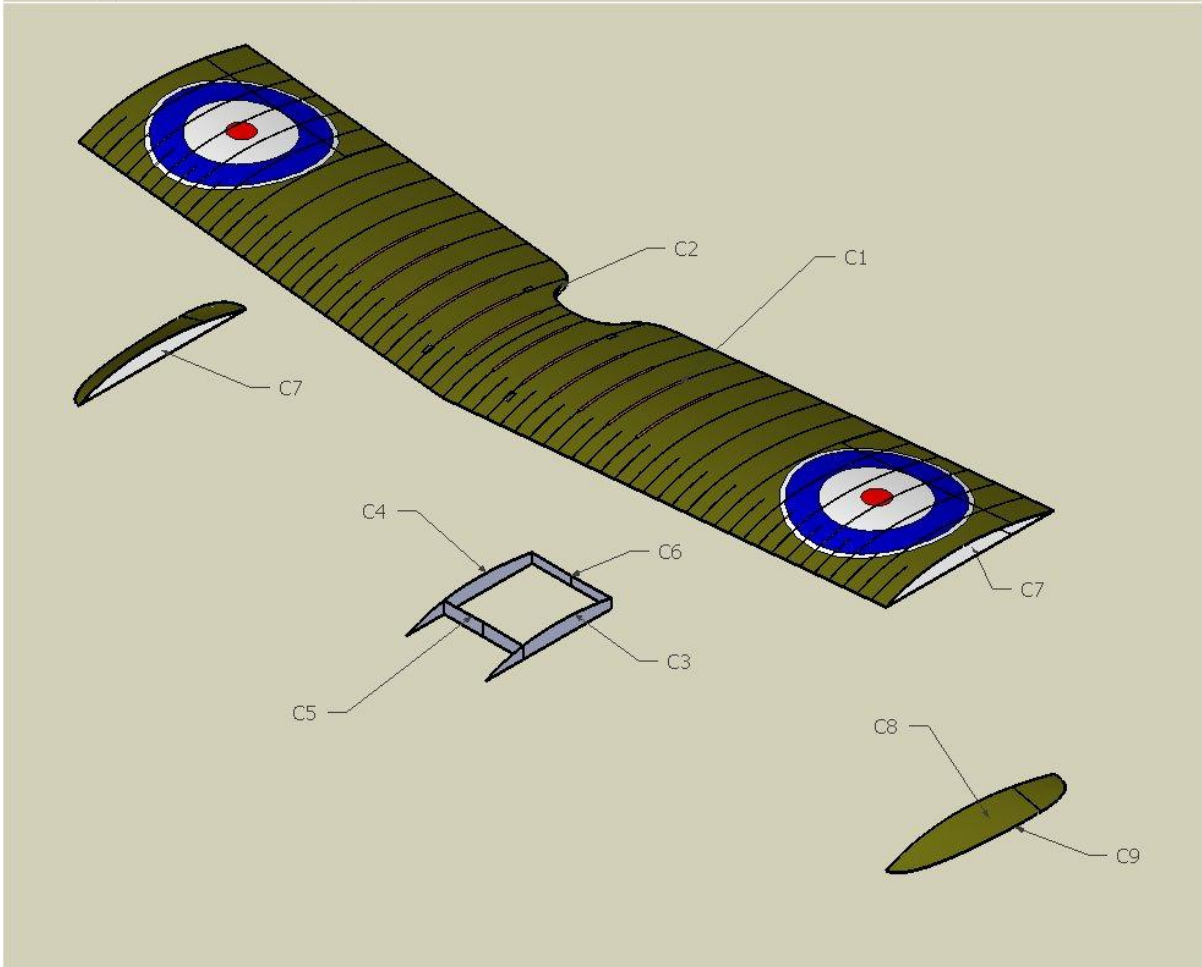
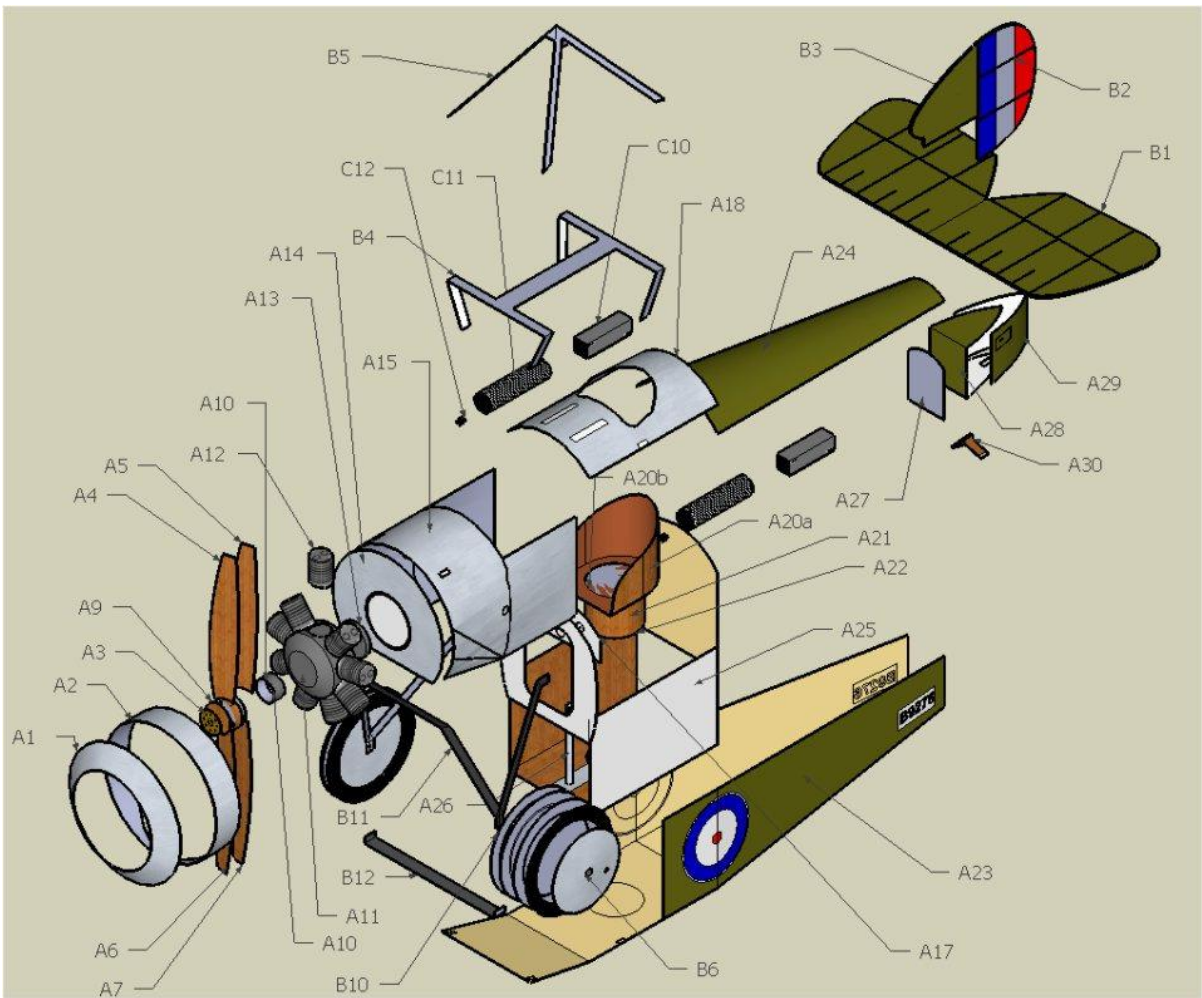

glue on cardstock

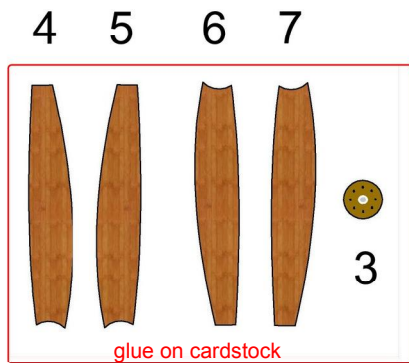
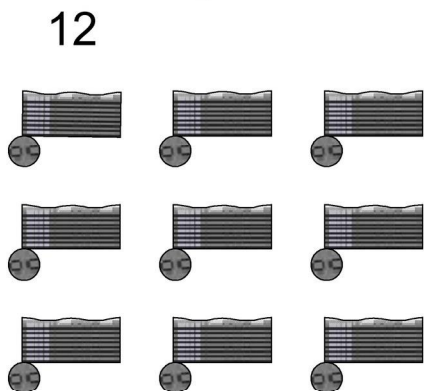
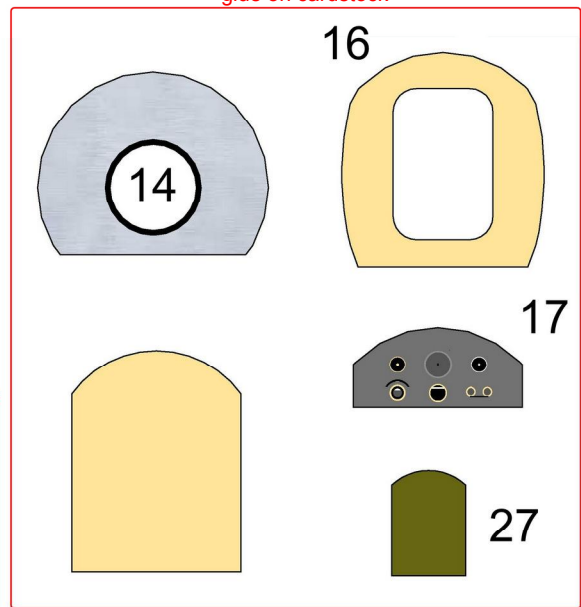
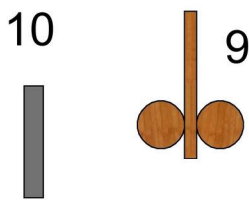
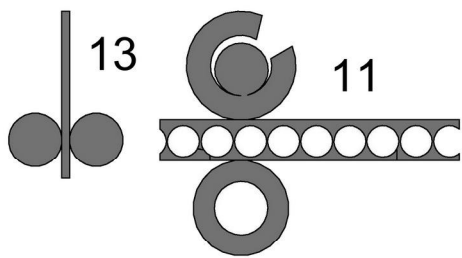

glue on cardstock

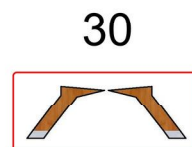
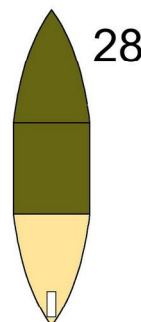
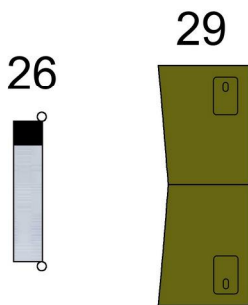
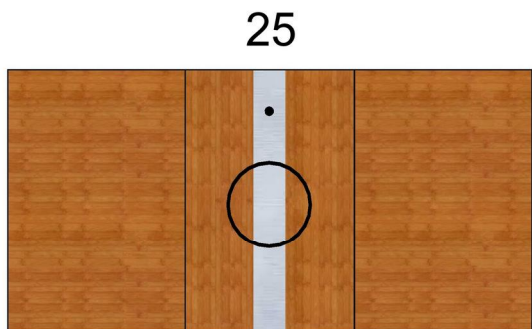
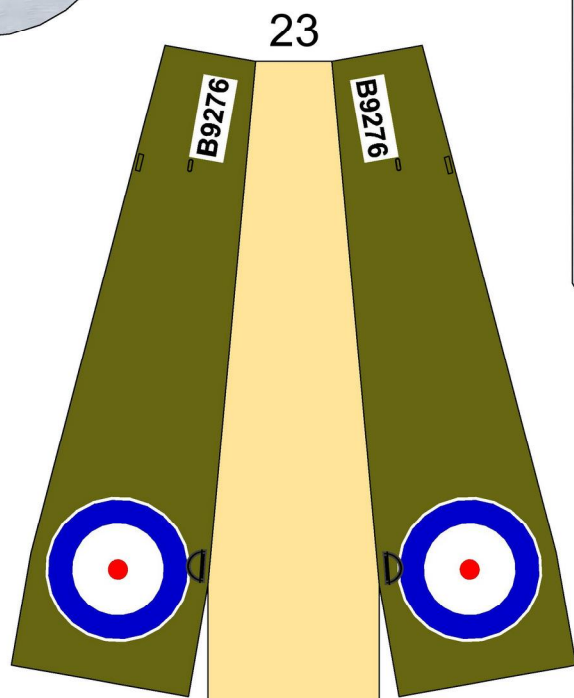
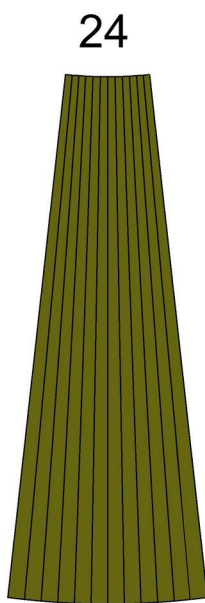
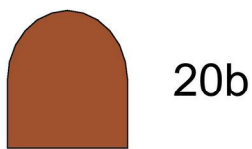
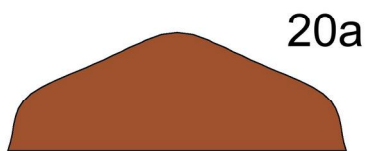
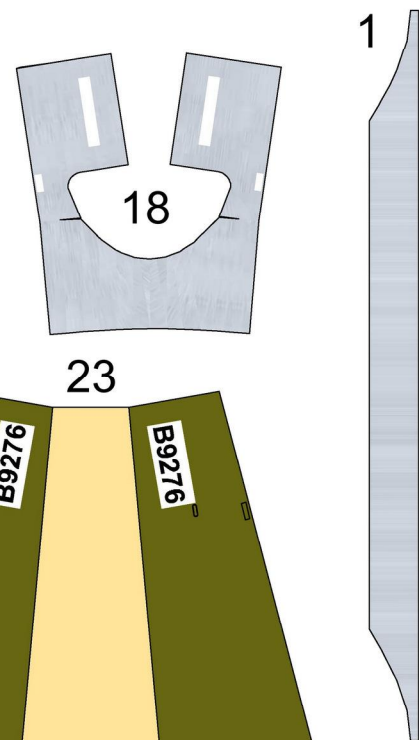
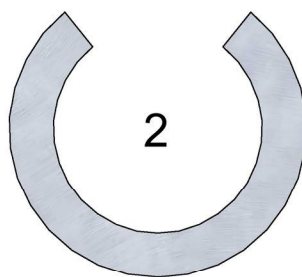
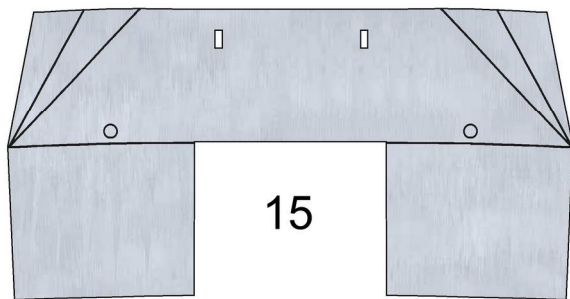

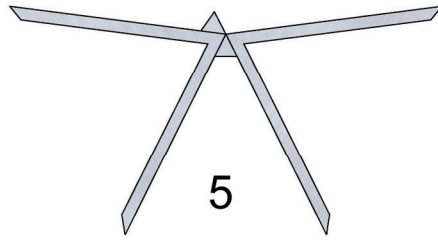
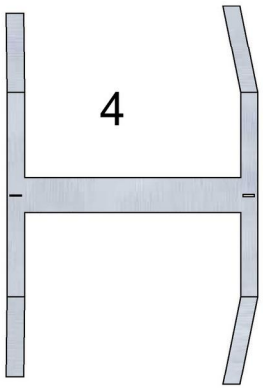
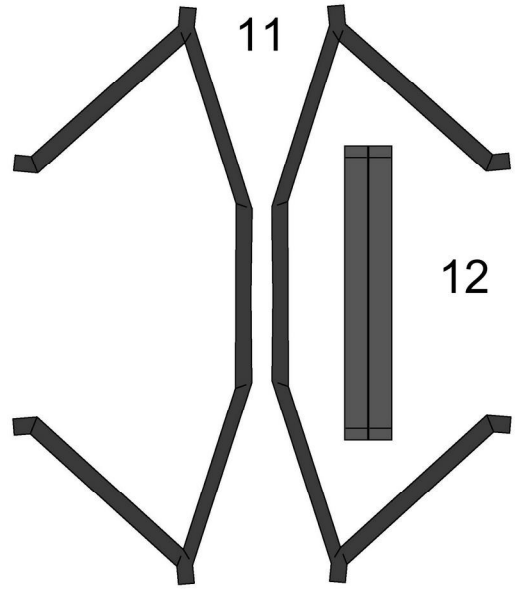
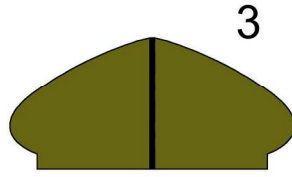
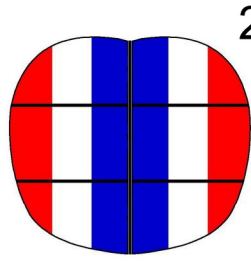
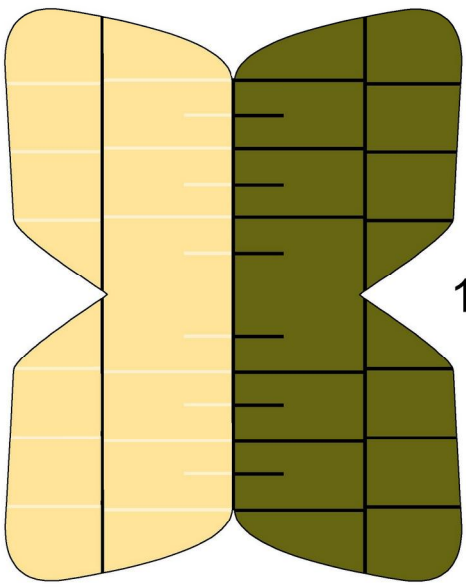

glue on cardstock

spare

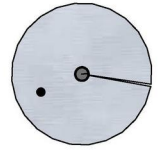
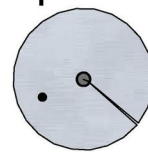

6

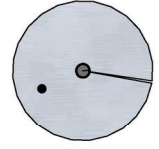
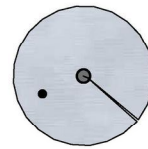

spare parts

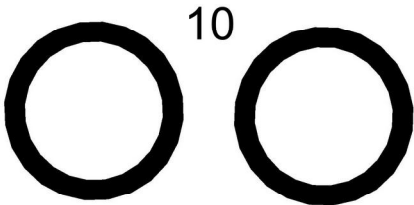

10

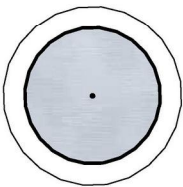

9

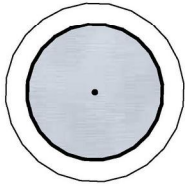

8

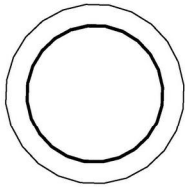
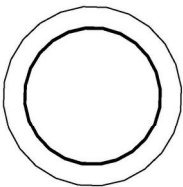

7

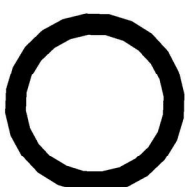
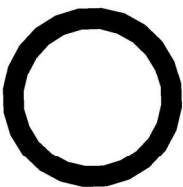

Sheet B - Copyright 2010 F.Santandrea

Not for commercial use

1 cm

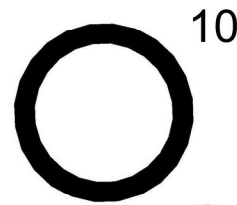

10

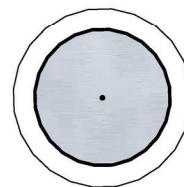

9

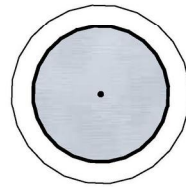

8

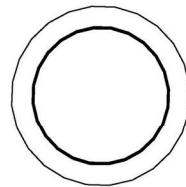
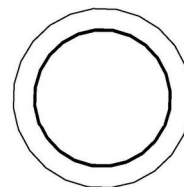

7

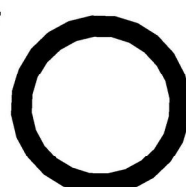
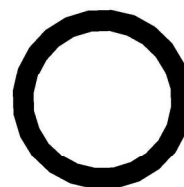

glue on cardstock

glue on cardstock

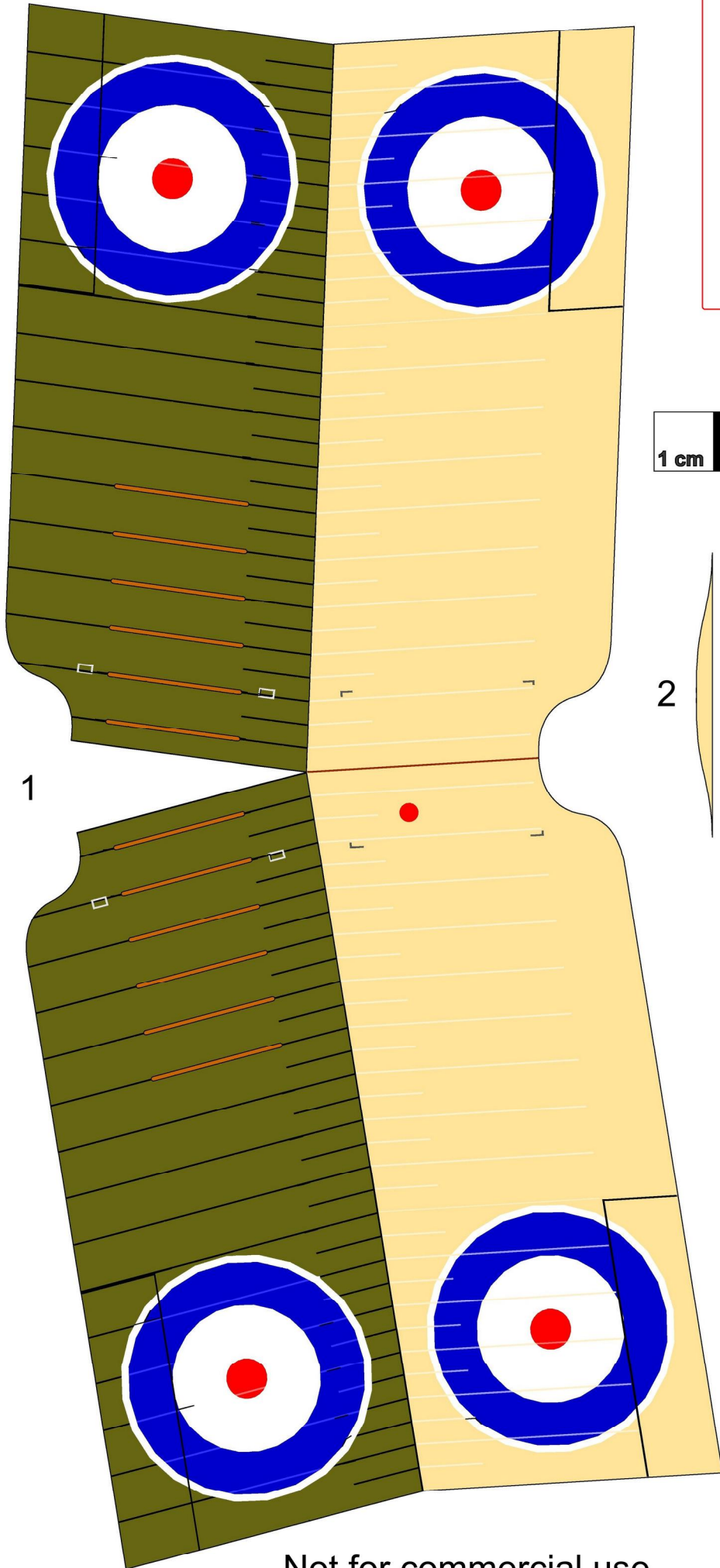

glue on cardstock

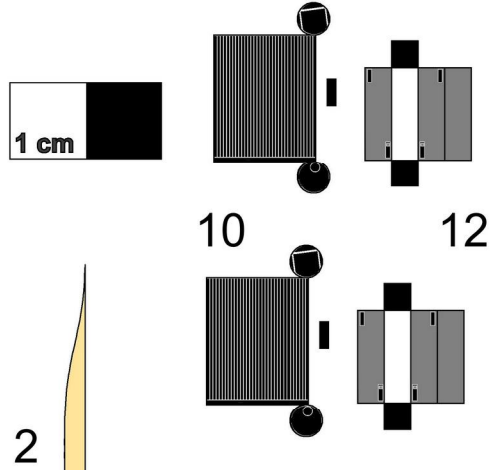
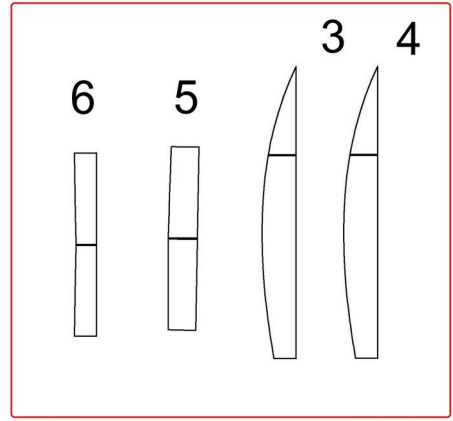

glue on cardstock

