

Energia

1:96 scale
rev. 3

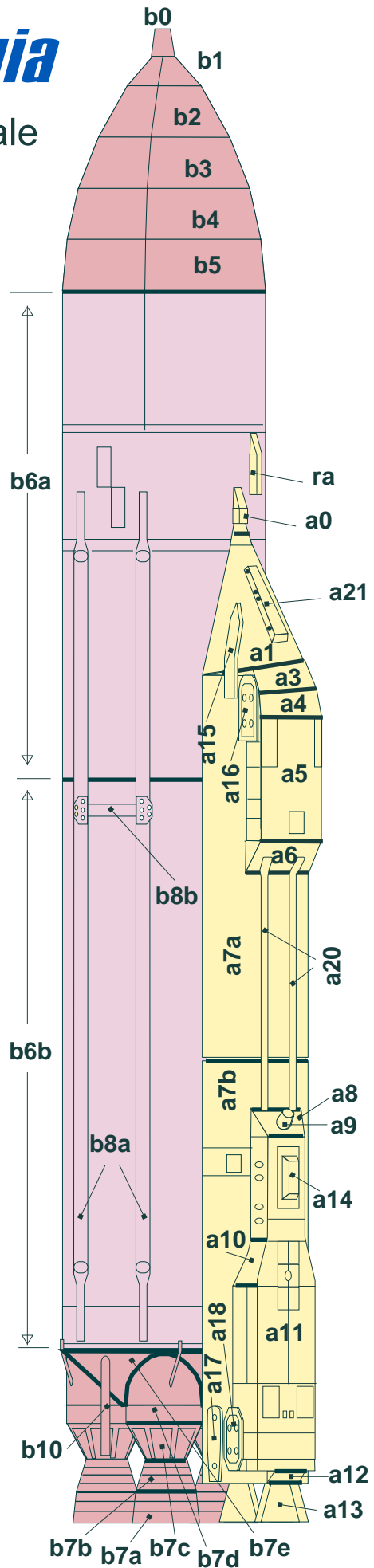
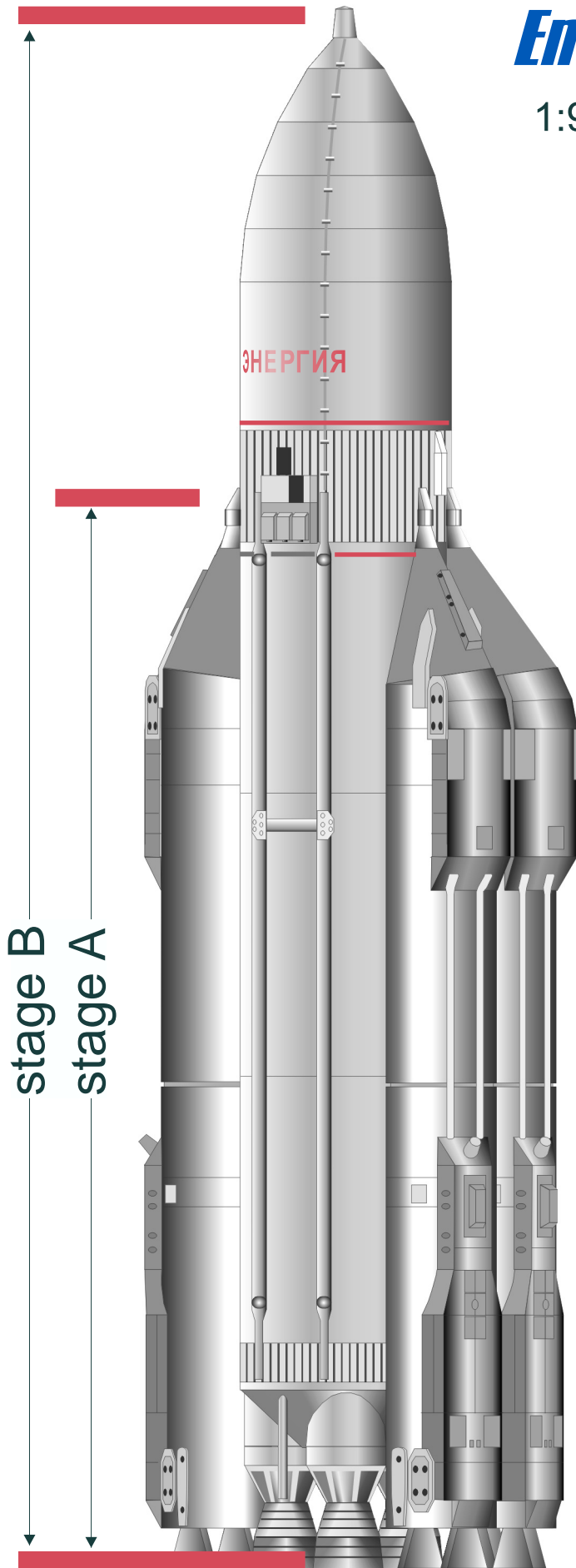

10 cm

b0

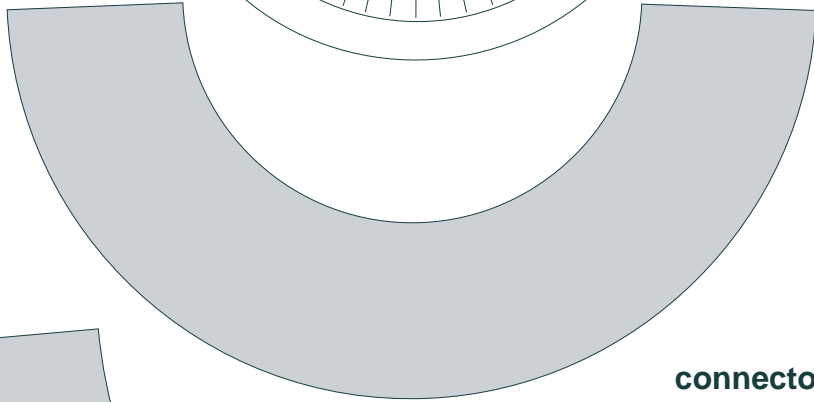
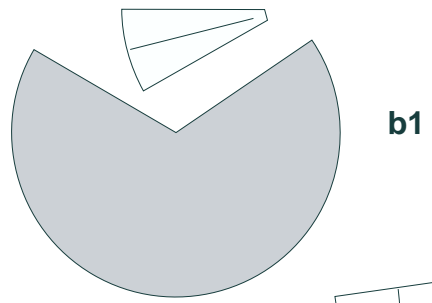
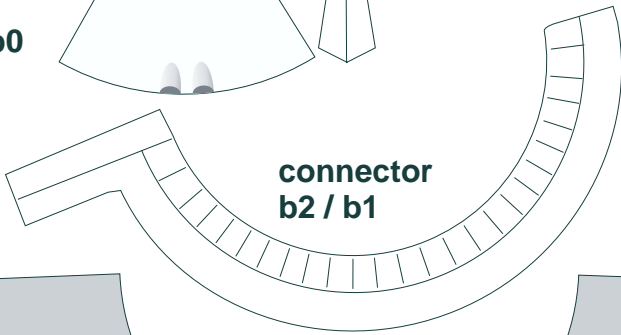
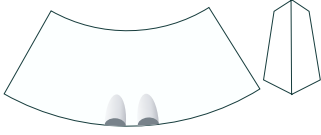

b2

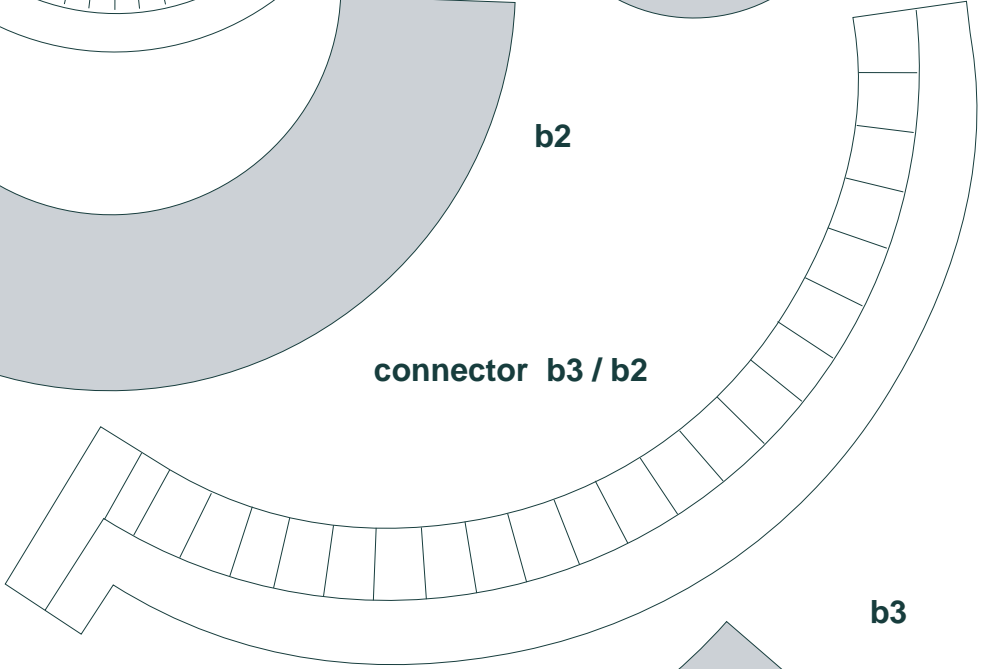

connector b3 / b2

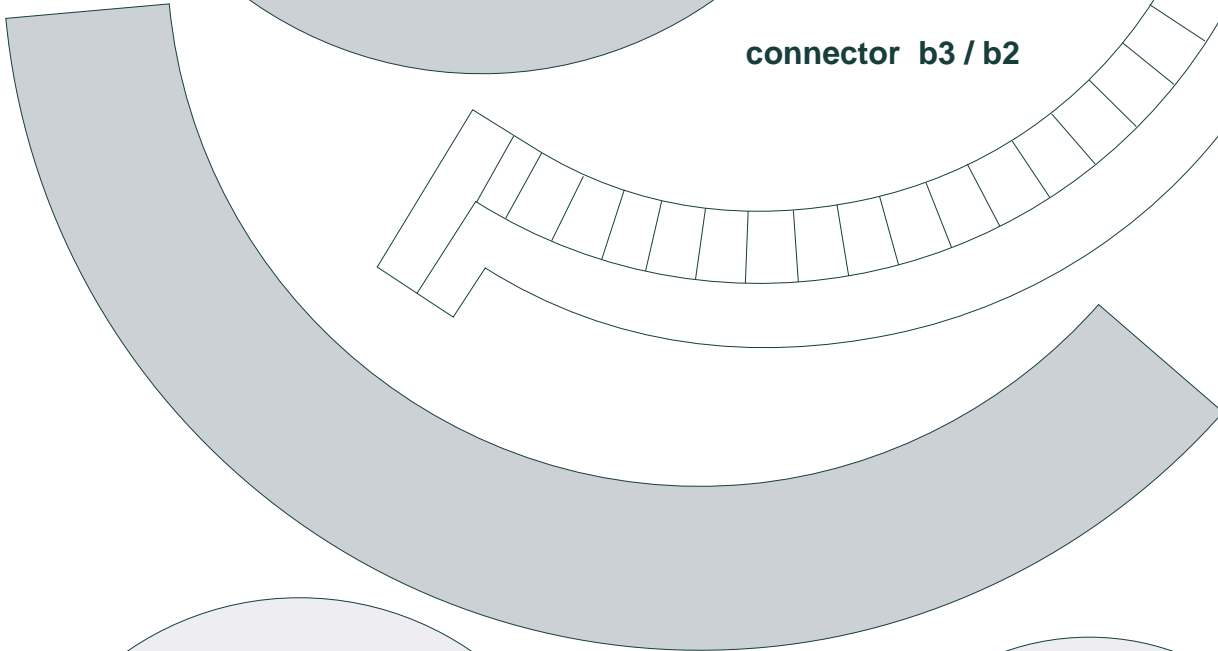

b3



disk into
bottom of b6

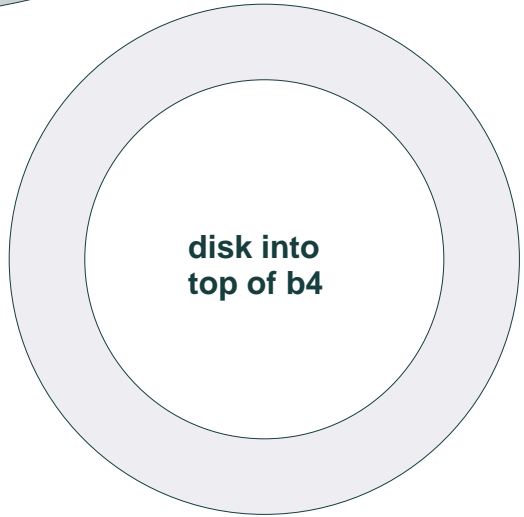

disk into
top of b4

10 cm

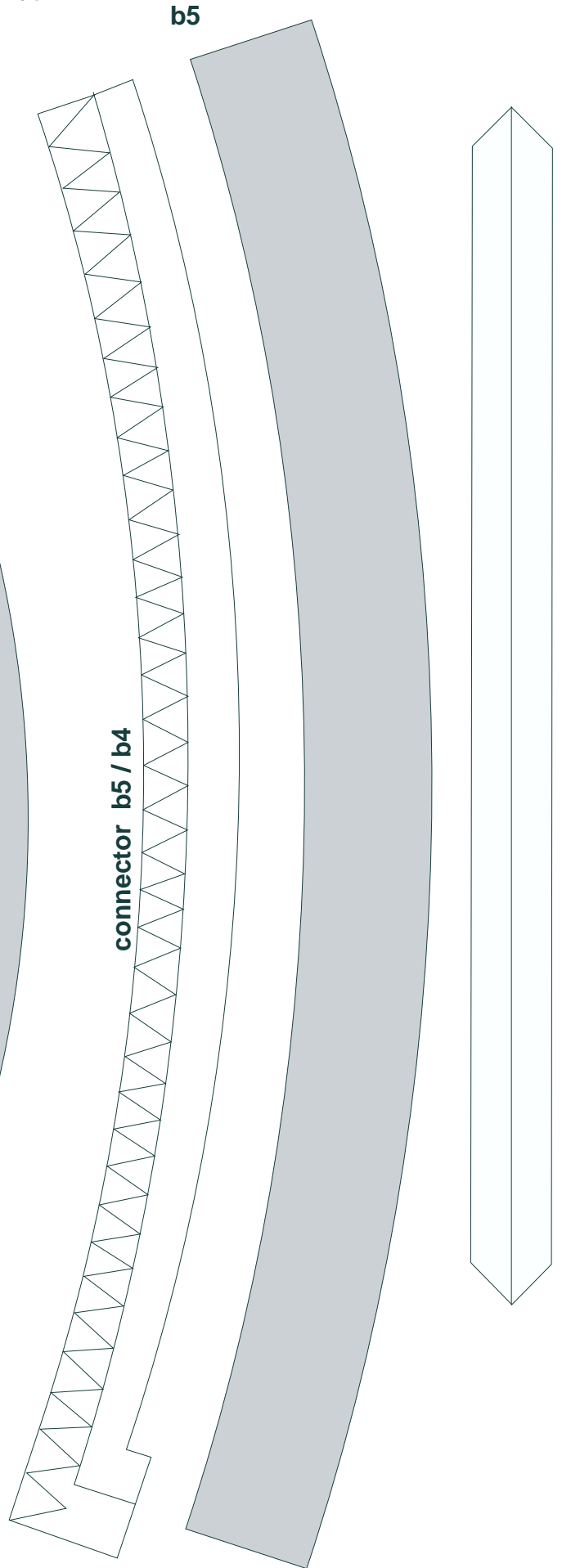
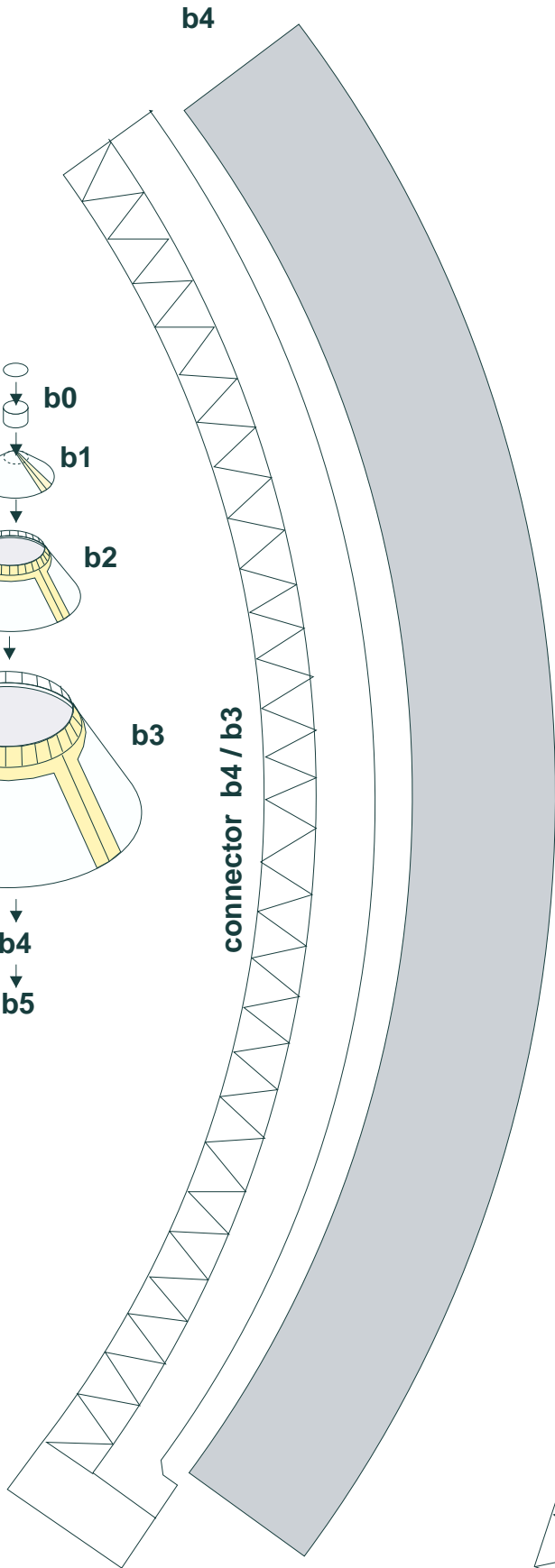
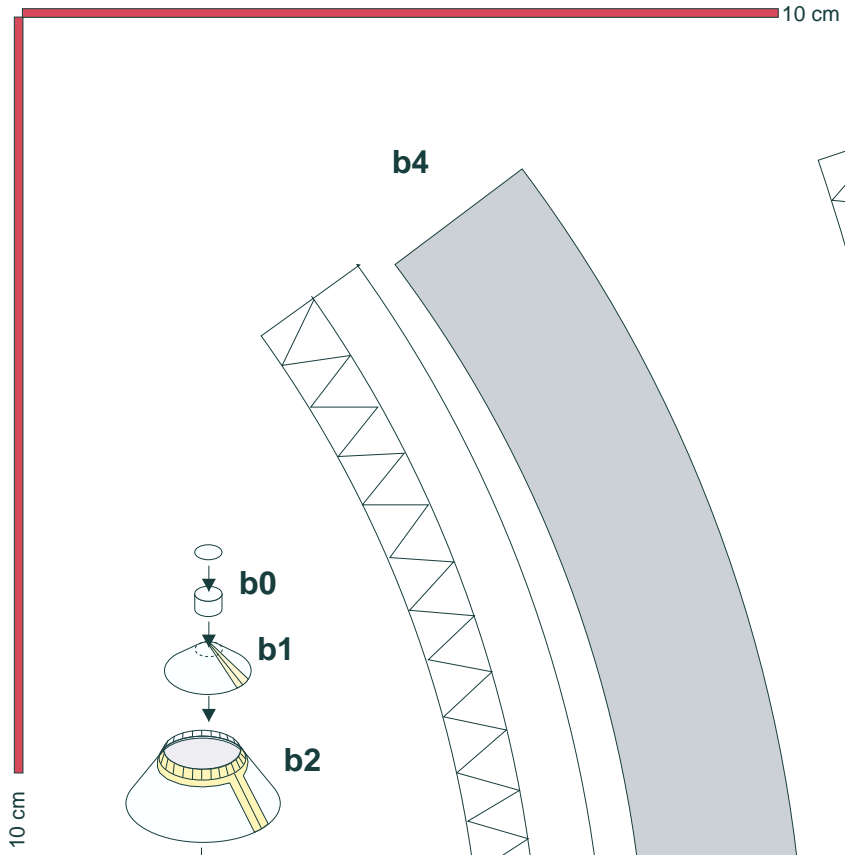

01

ЭНЕРГИЯ

02

03

05

05

05

05

04

ra

10 cm

© 2006 Designed by L.Cherkashyn This cardmodel is only for personal and not for commercial use

ЭНЕРГИЯ

01

01-p

02

03

05

05

05

05

04

ra

ra

10 cm

© 2006 Designed by L.Cherkashyn This cardmodel is only for personal and not for commercial use

Additional details for two versions of Energia

- 1 - first launch
- 2 - second launch

2 Buran - Energia

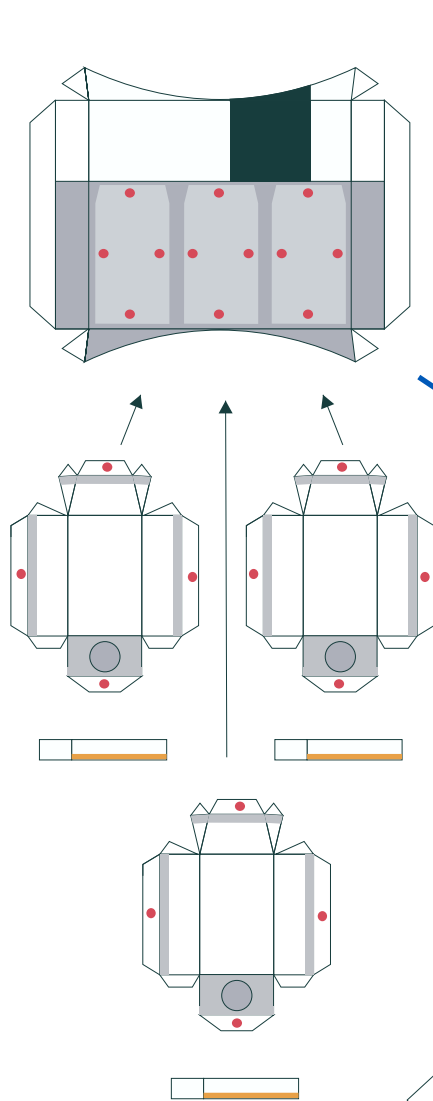

1 Polyus - Energia

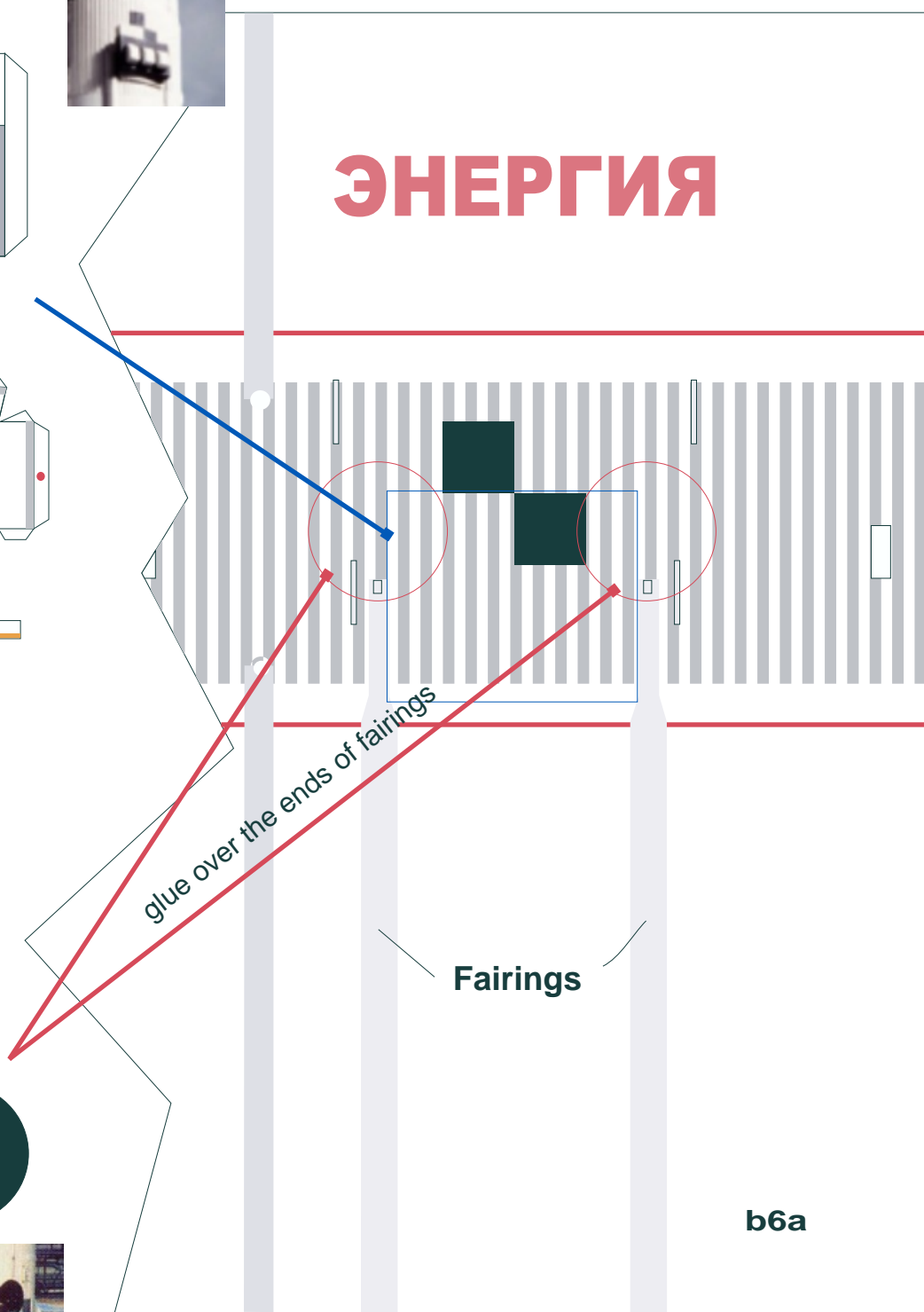
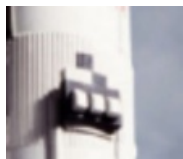
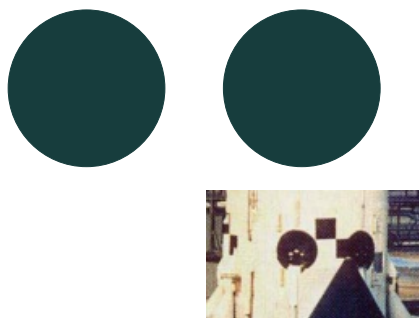

10 cm

© 2006 Designed by L.Cherkashyn This cardmodel is only for personal and not for commercial use

Print on cardstock Body of B

10 cm

10 cm

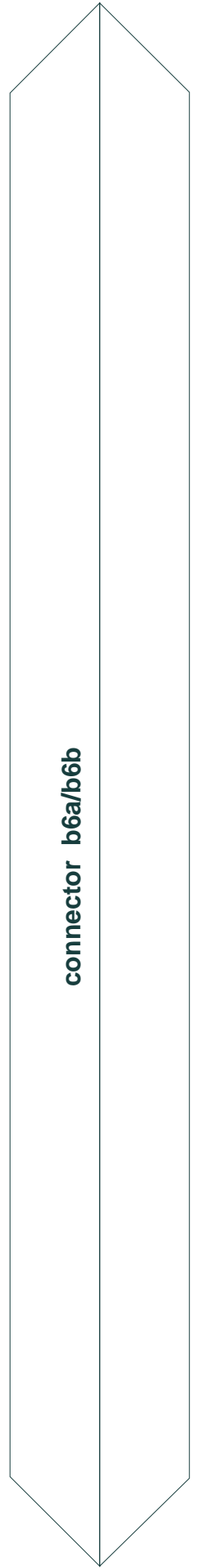
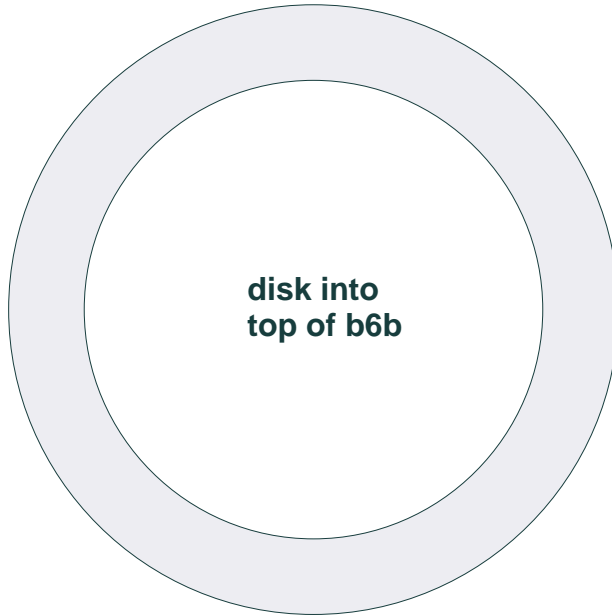

10 cm

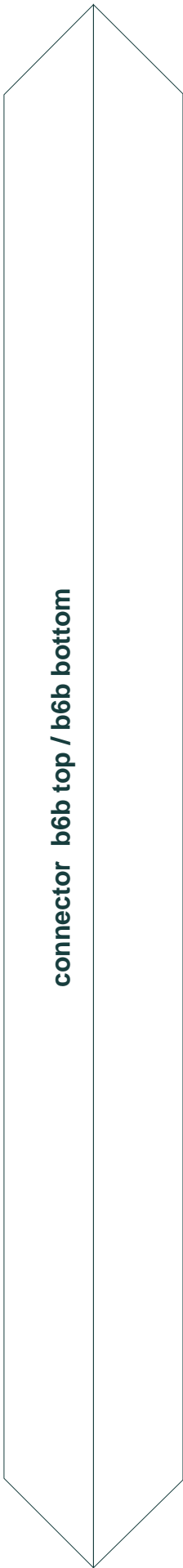
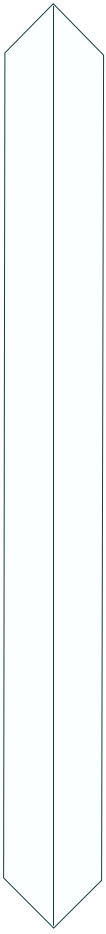

connector b6b top / b6b bottom

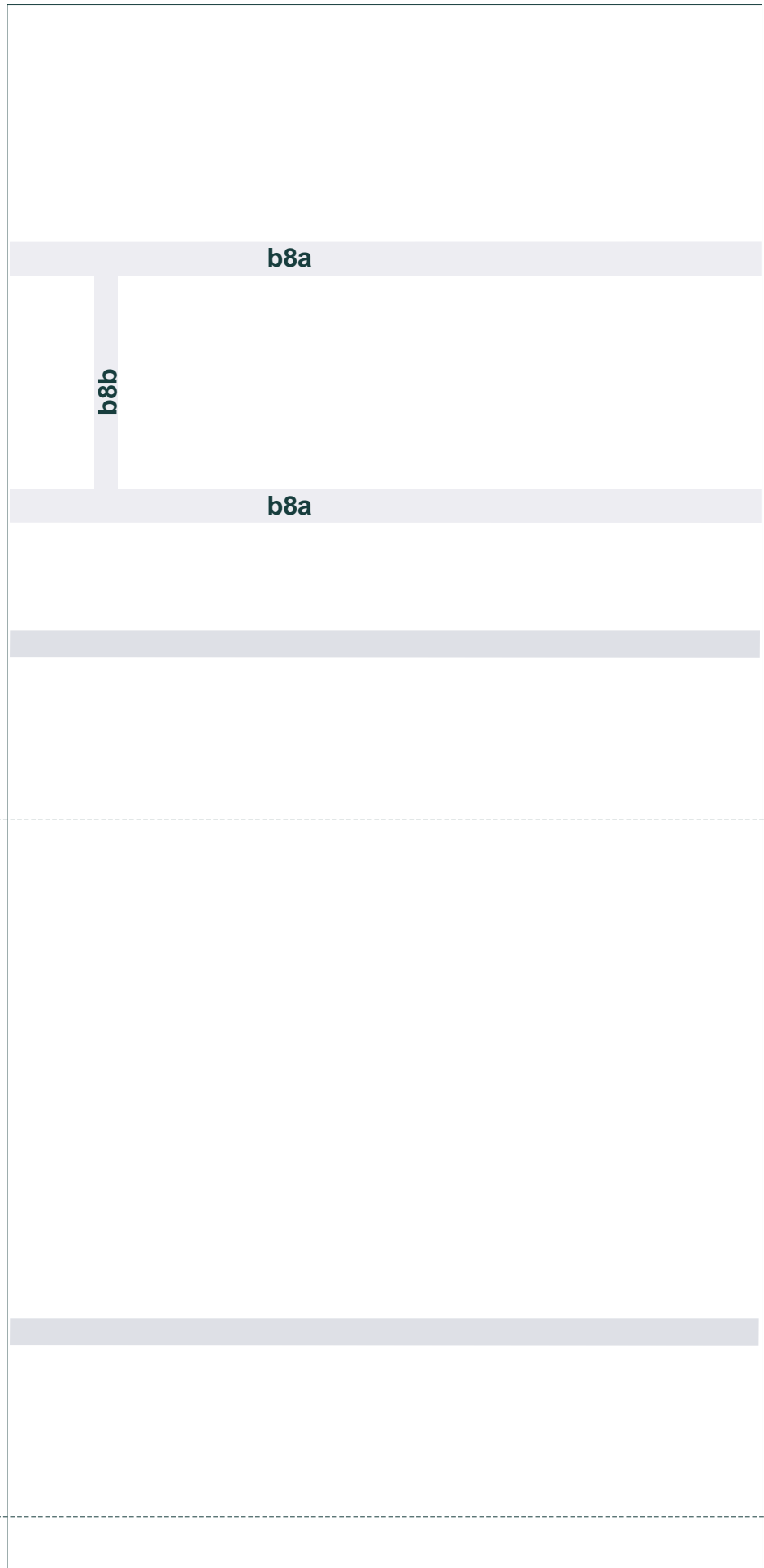

b8a

b8b

b8a

b6b top

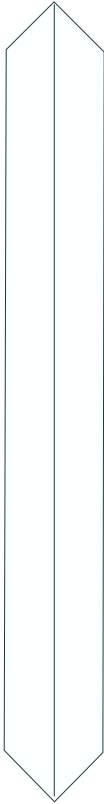
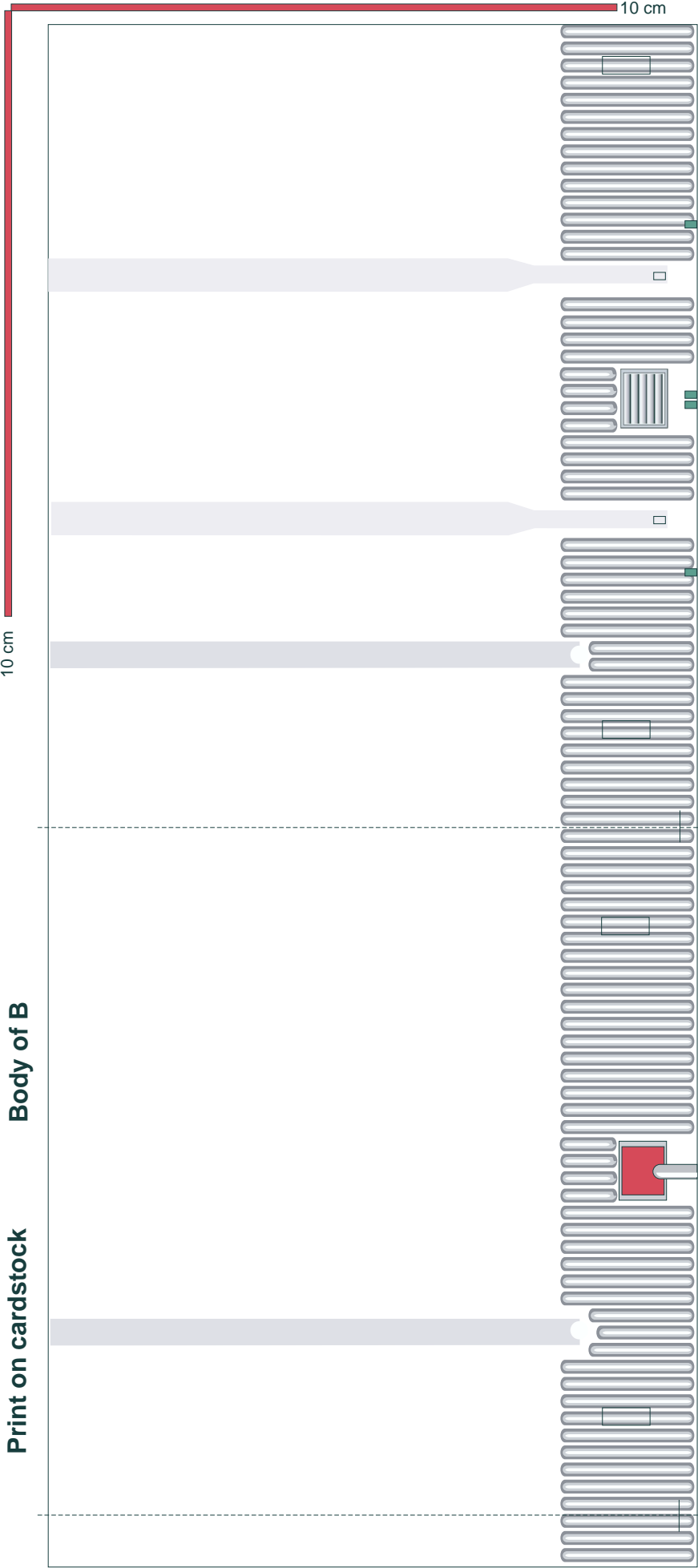

b6b bottom

base lines for assembling pairs of blocks A

Page 6

connector b6b / b6 bottom



supporting ring for disk



supporting ring for disk



10 cm

b10

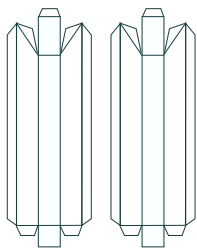
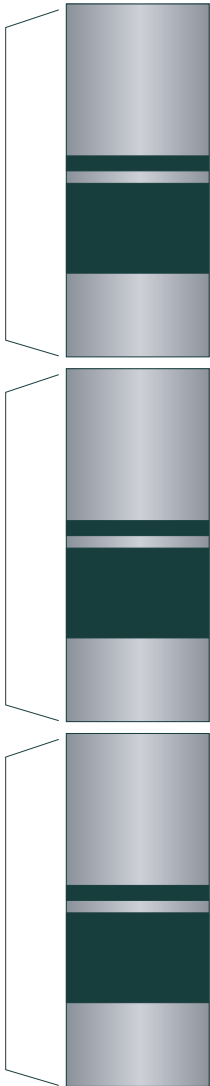

ra

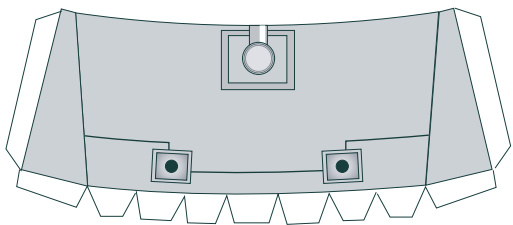

b9a

b7e optioned

First necessary to cut along the broken line (1). The OUTER DUCT (2) of the figure to cut only after its gluing by connector 1.

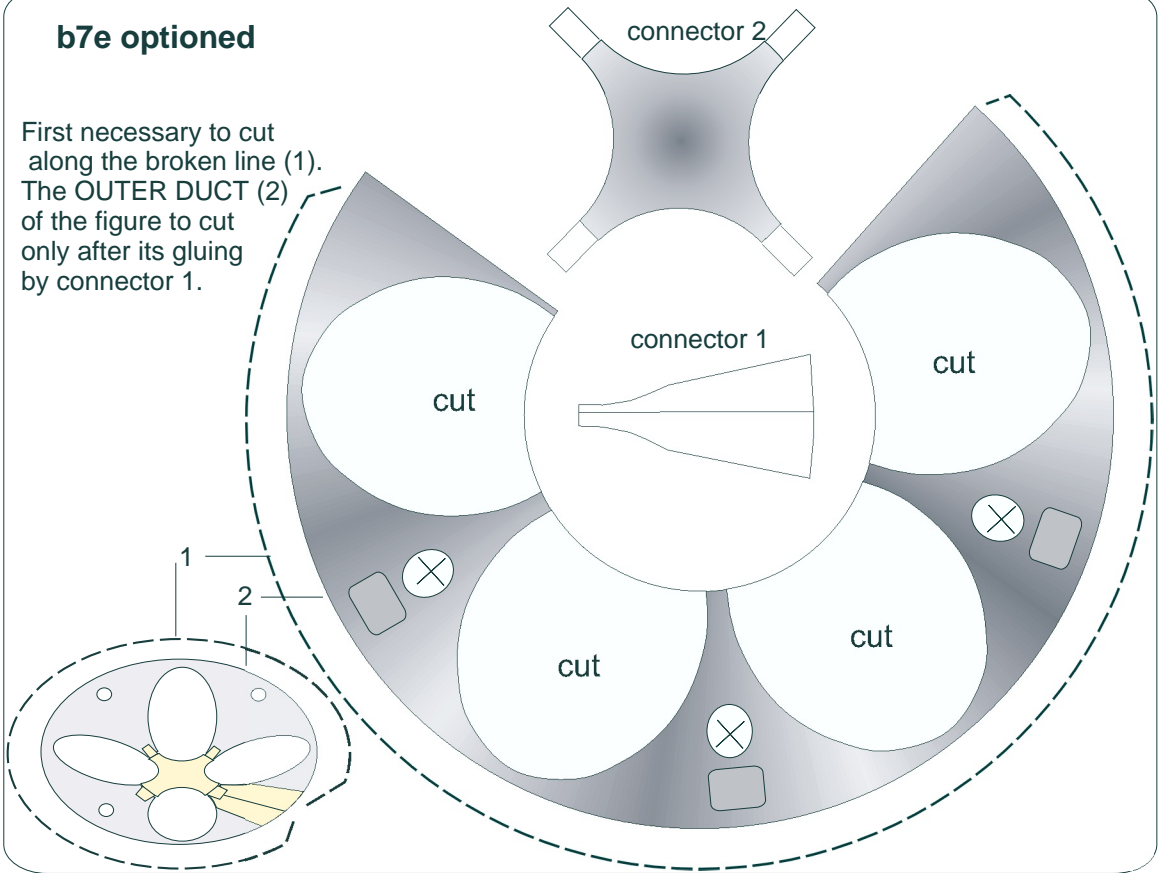

b22

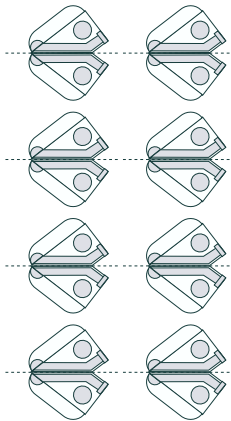

glue onto cardstock

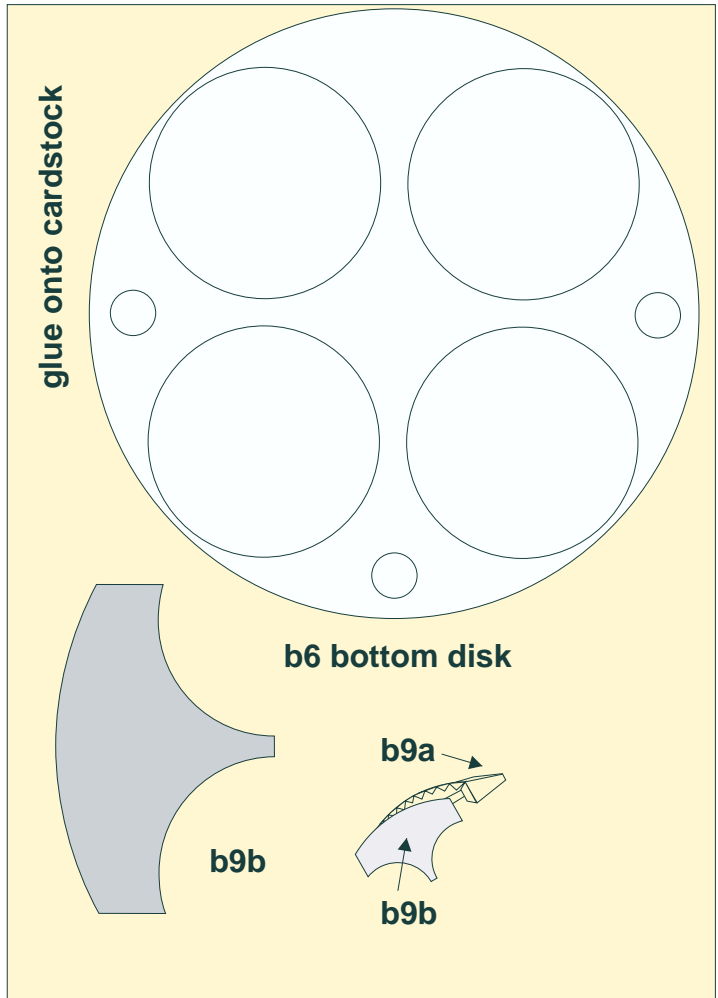

b6 bottom disk

b9b

b9a

b9b

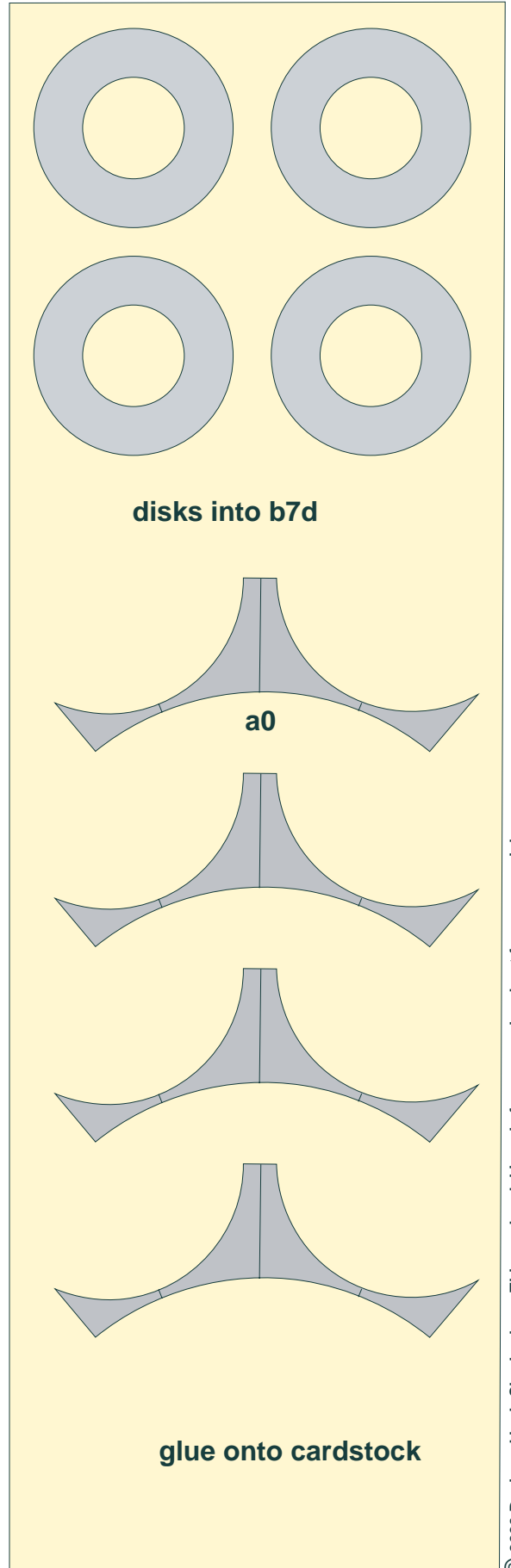
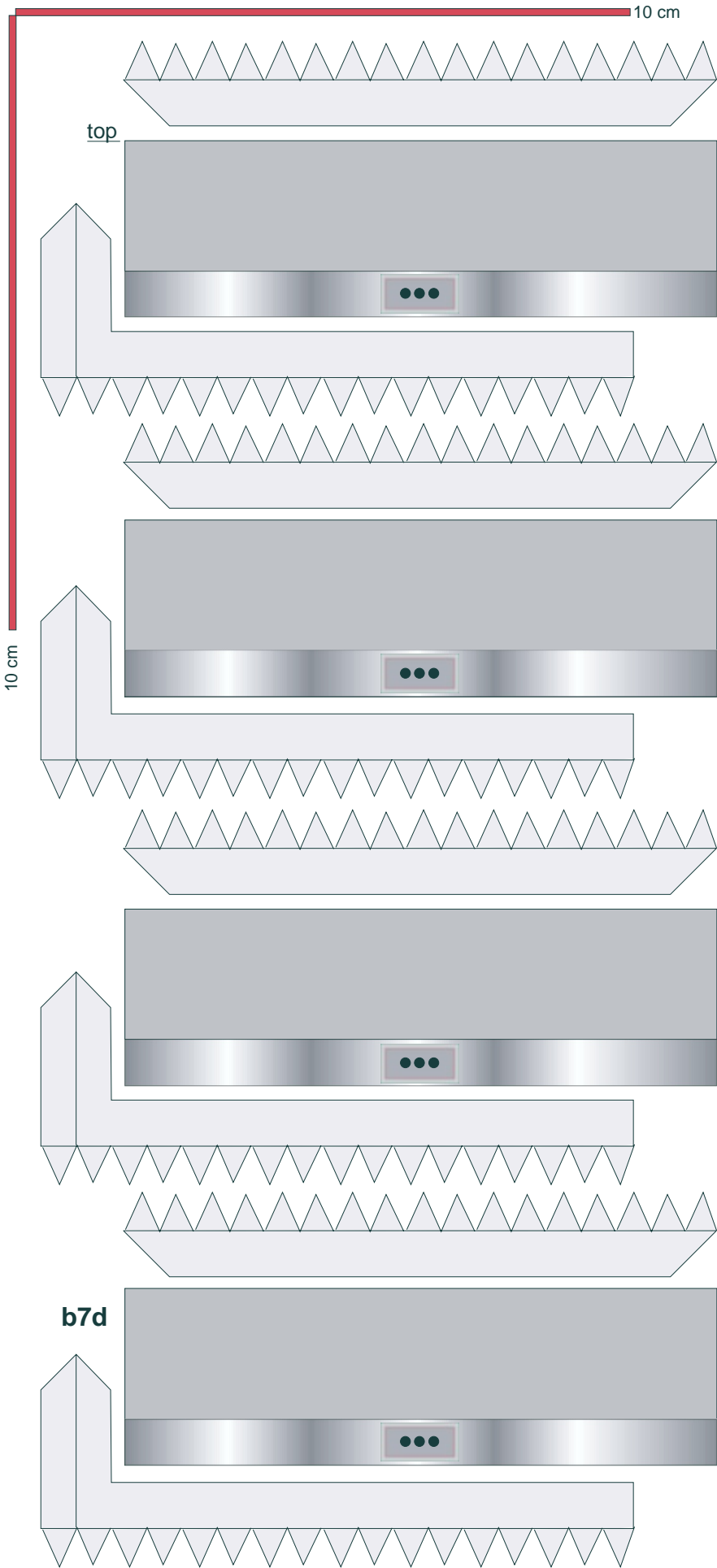

b7c

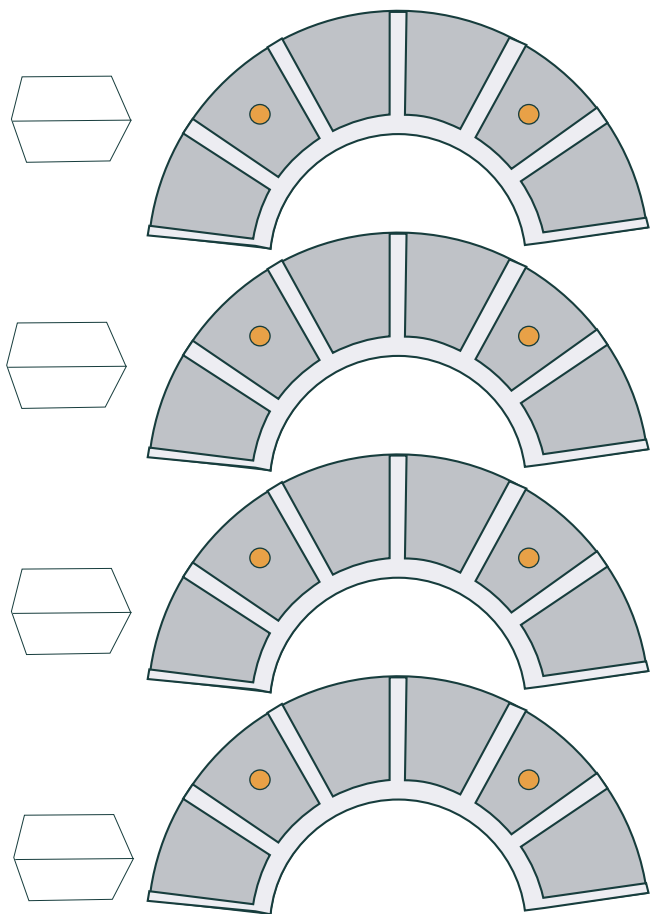

connectors b7b / b7c

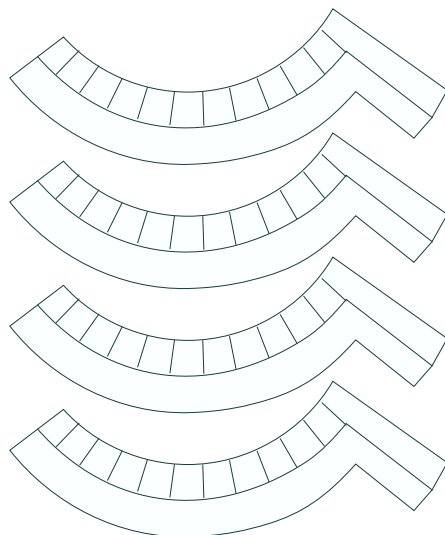

b7b

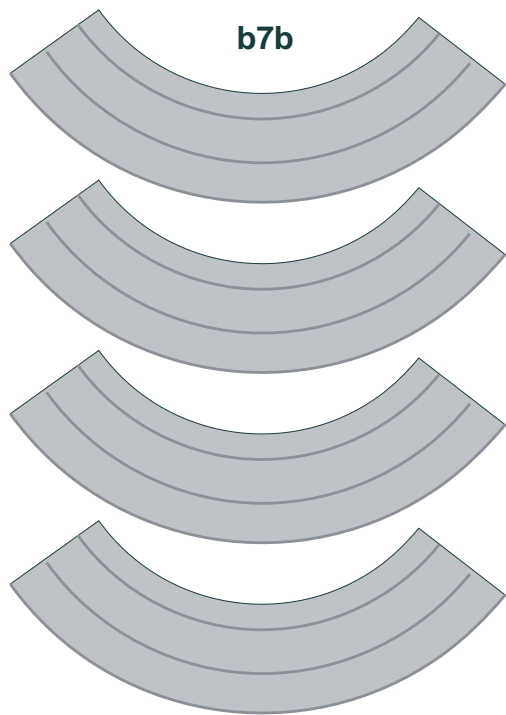

connectors b7a / b7b

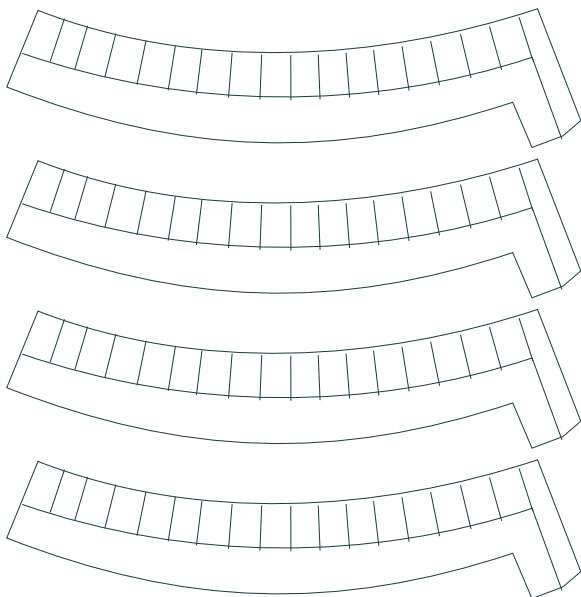

b7a

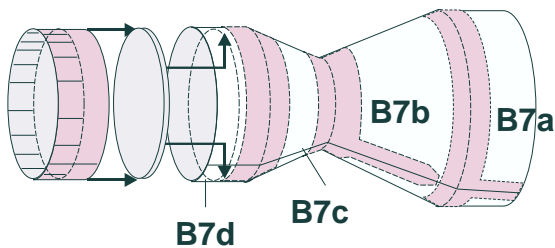
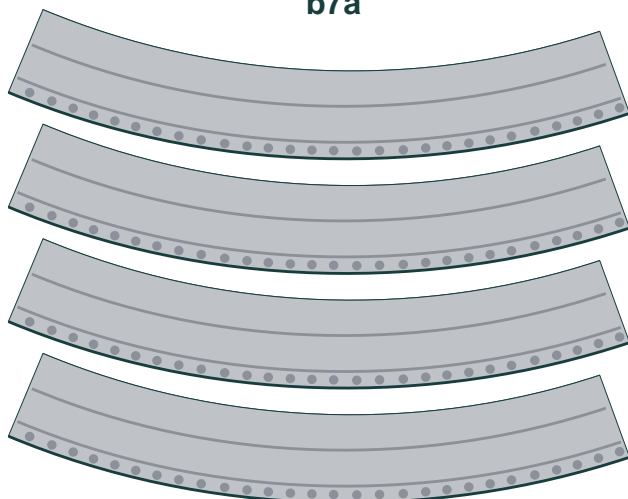

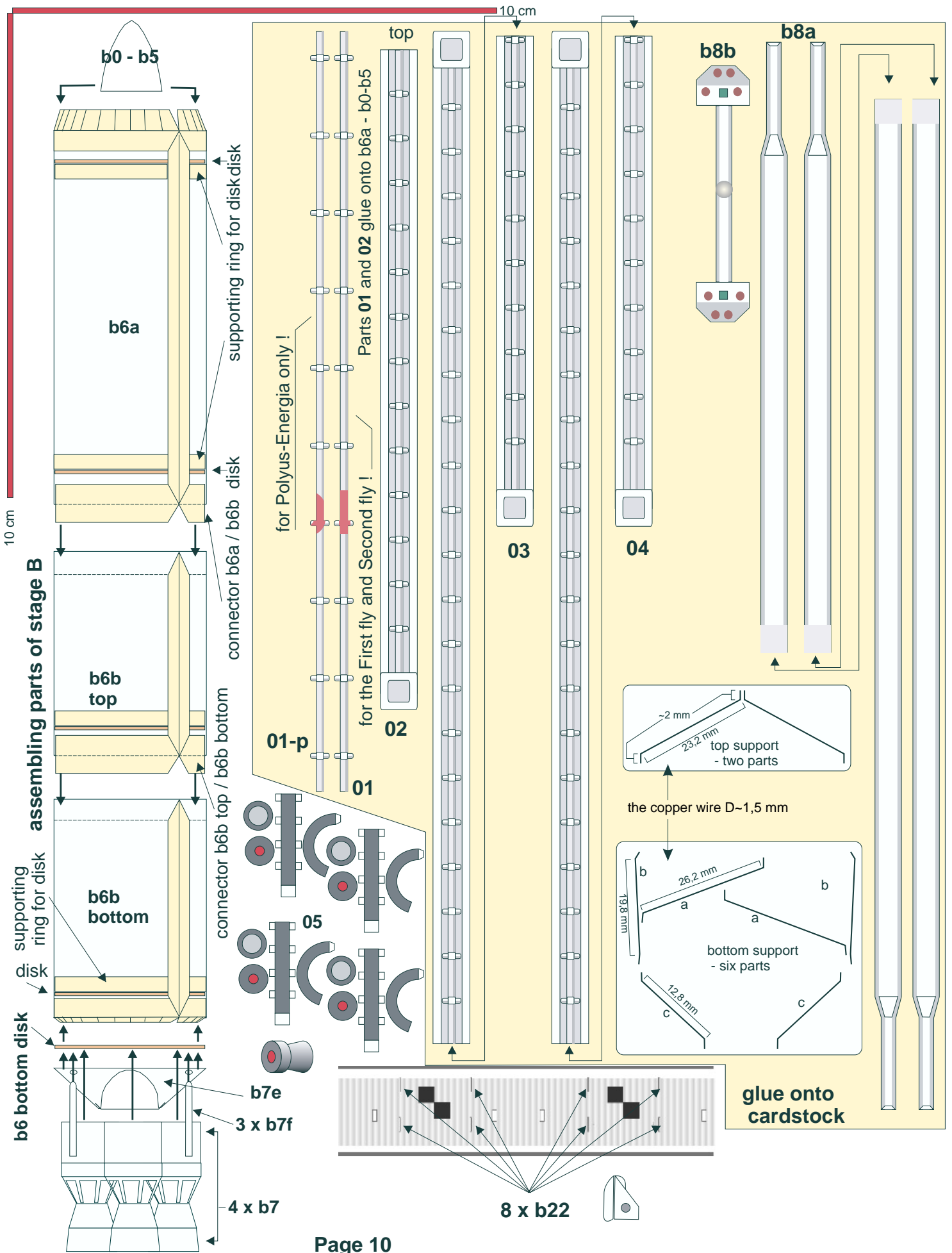

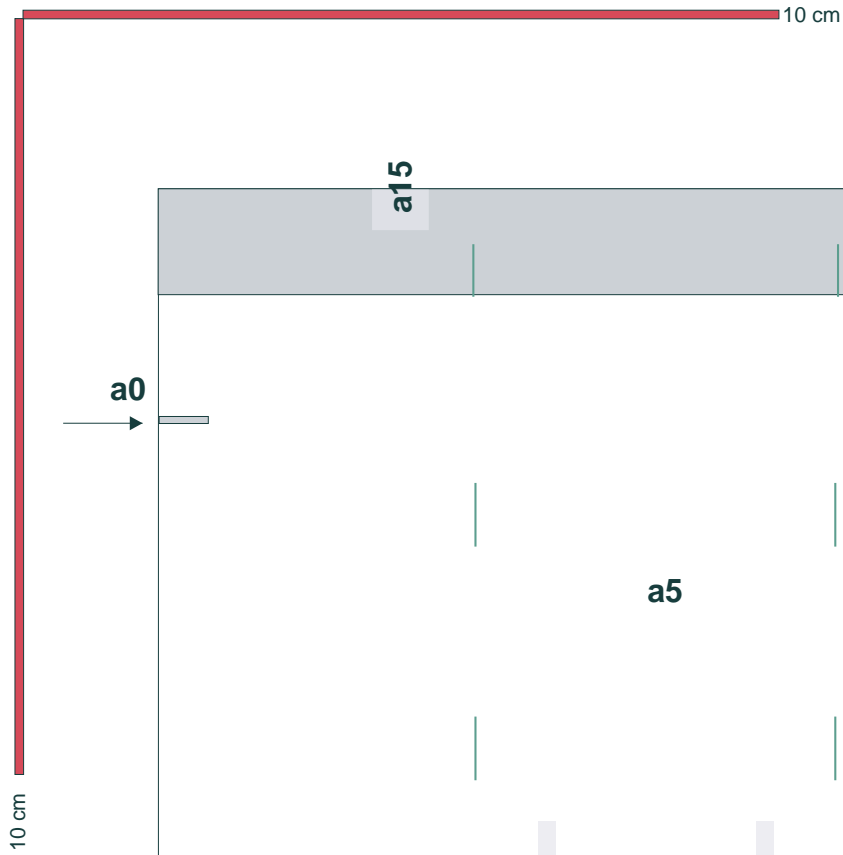

— slots

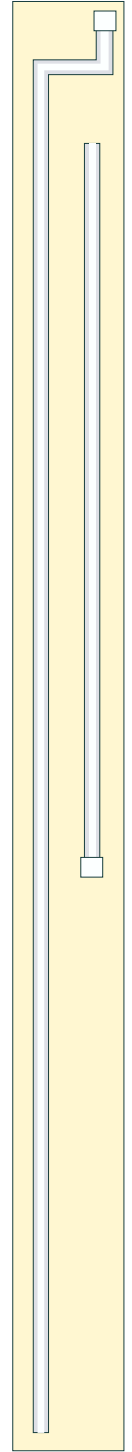
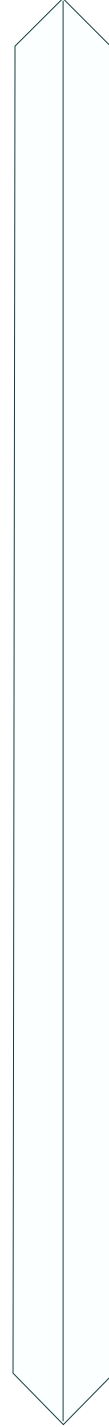

A1

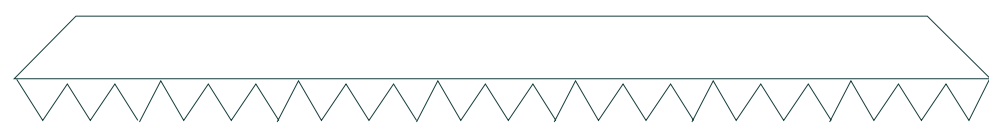
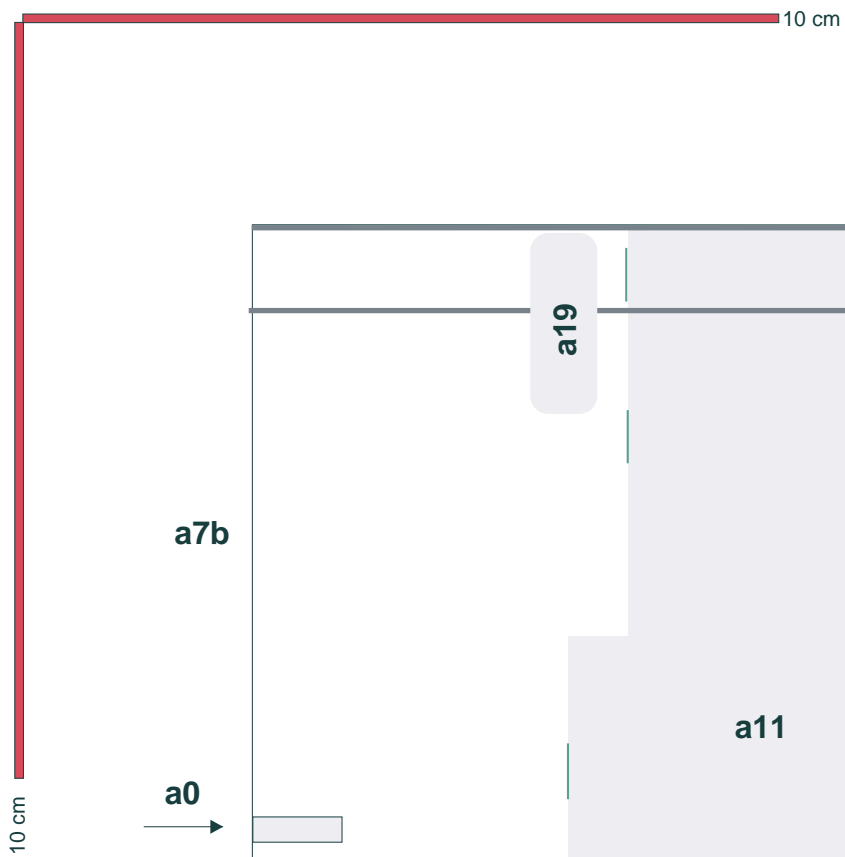

— slots

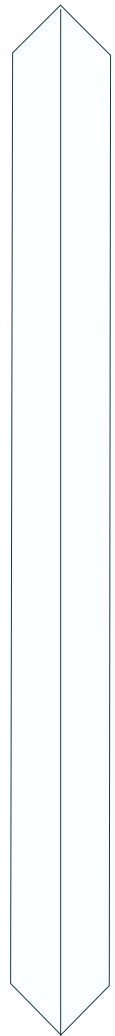

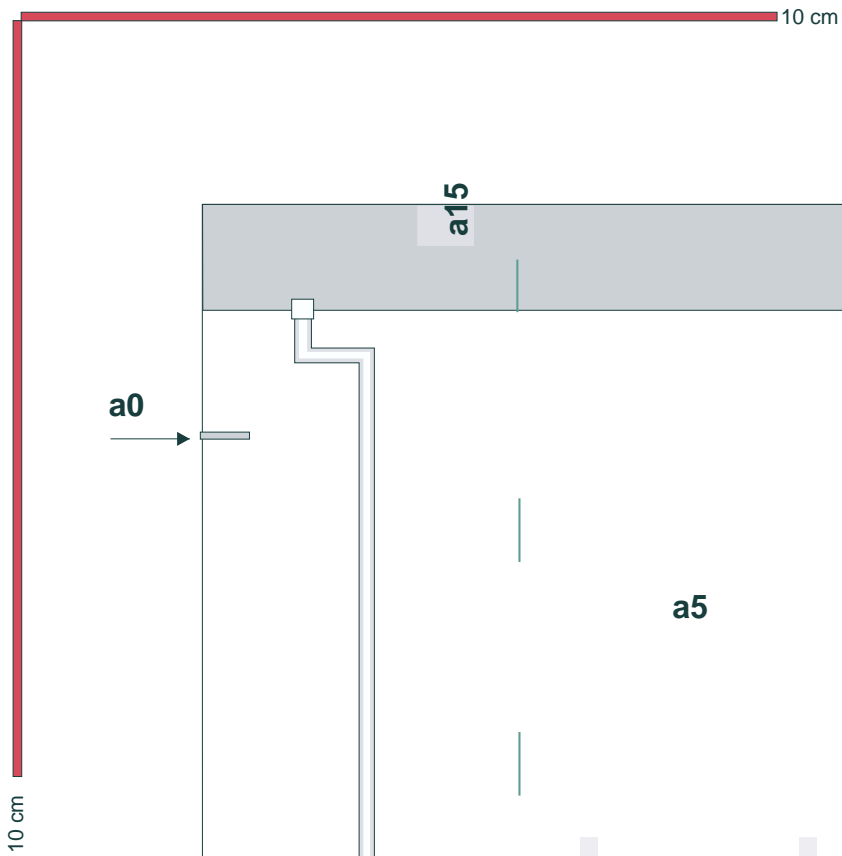

— slots

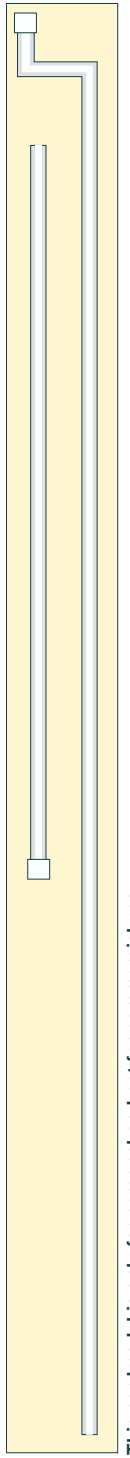
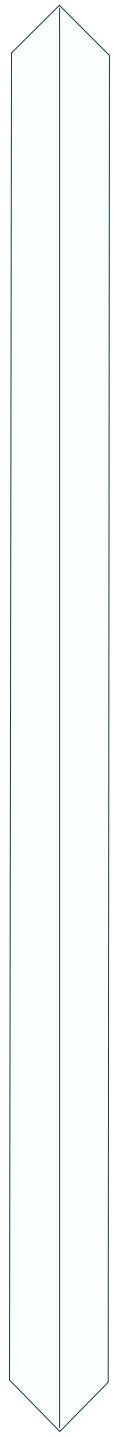

A2



— slots

A2

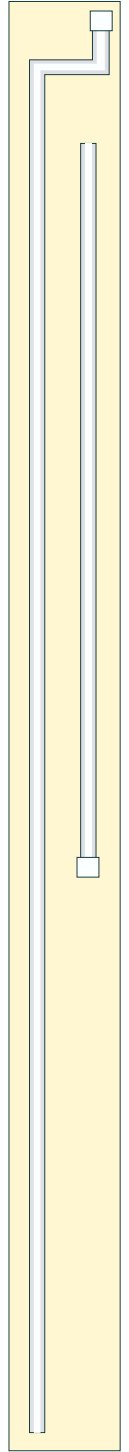
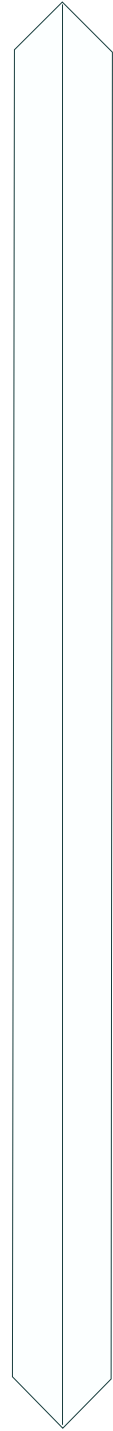
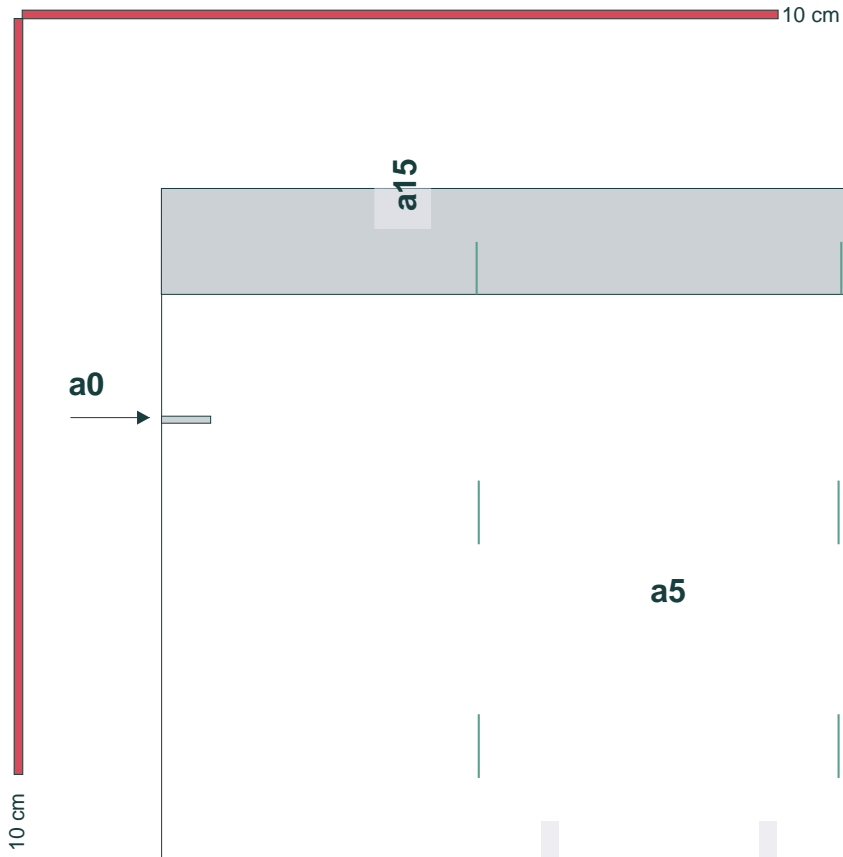

A3

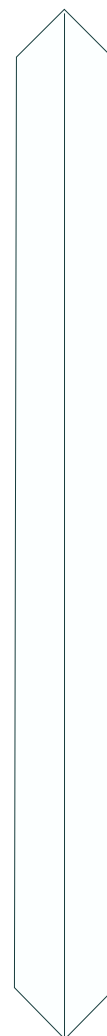
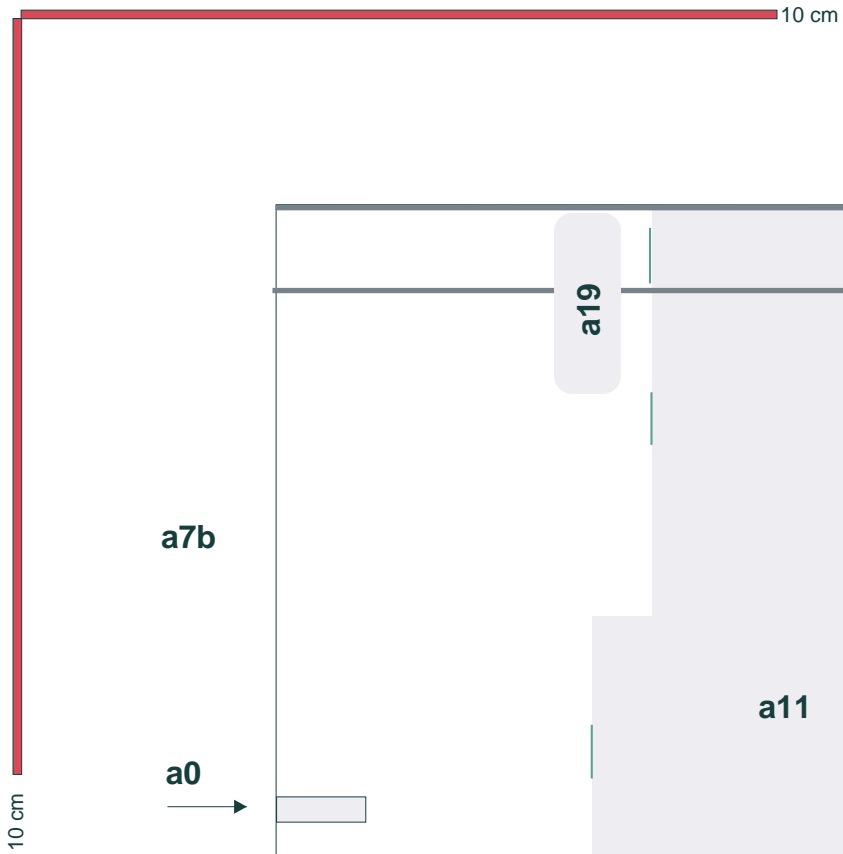

connector a7a / a7b



— slots

A3

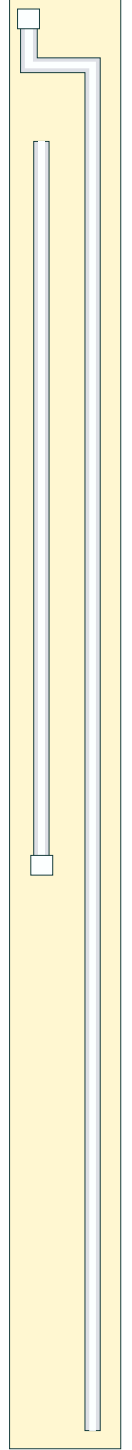
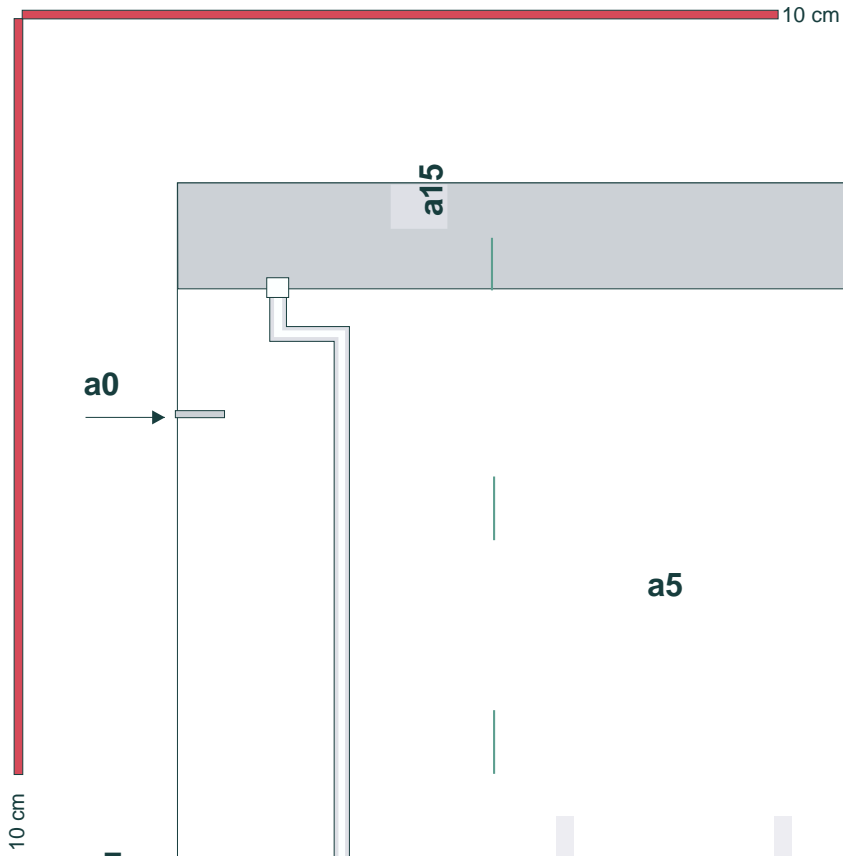

A4

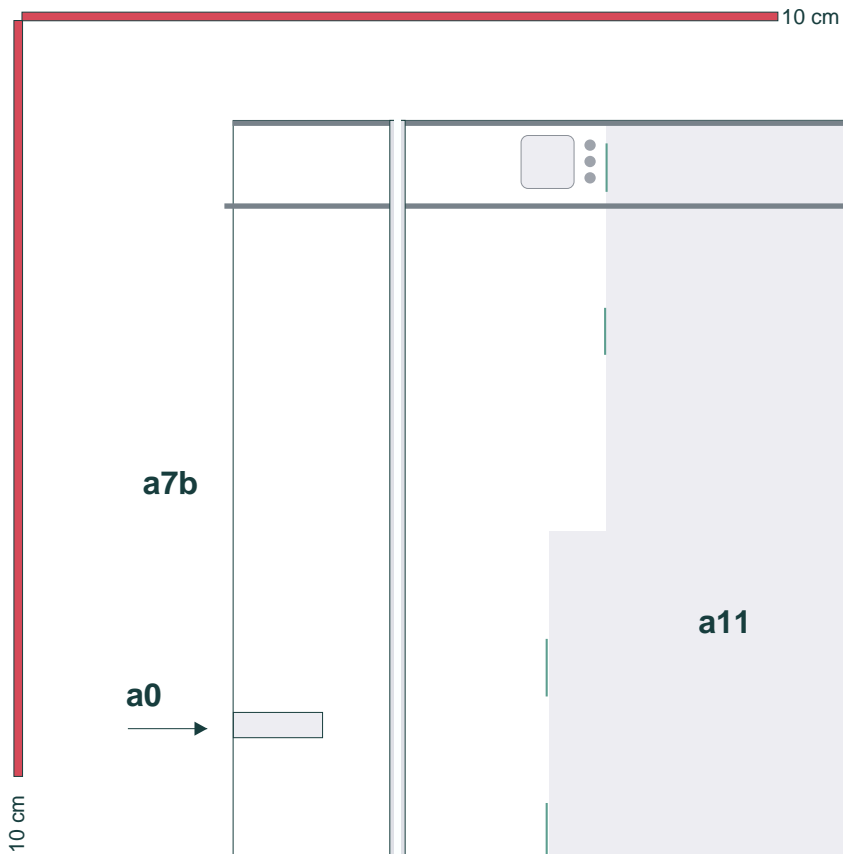

connector a7a / a7b



— slots

A4

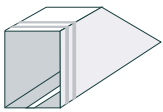
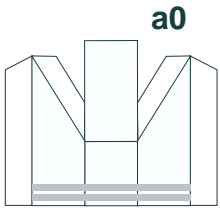
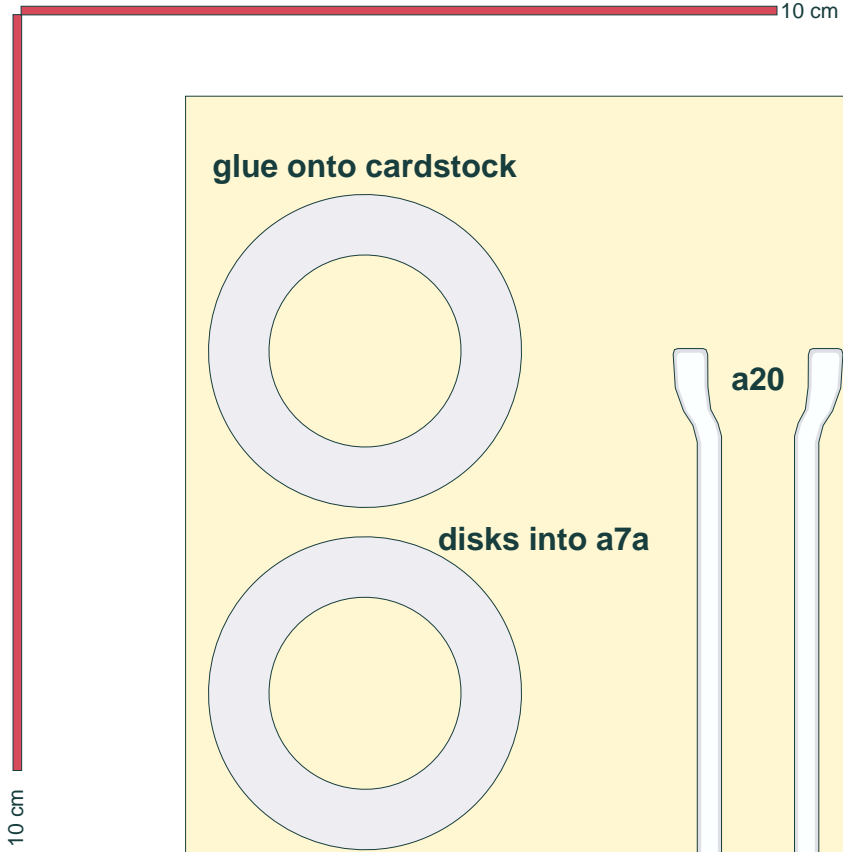

Details for stage A
Print 4 copies

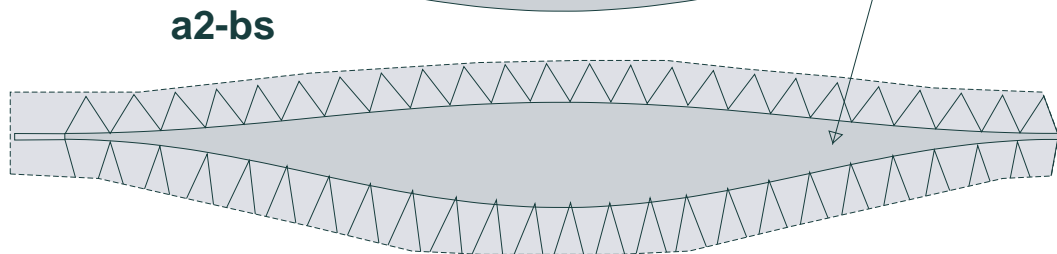
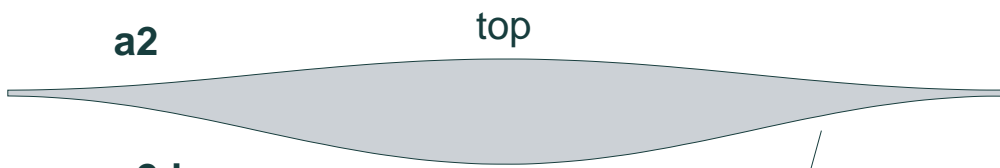
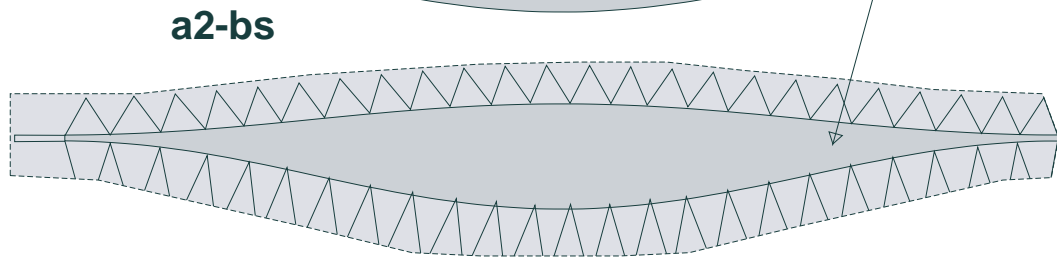
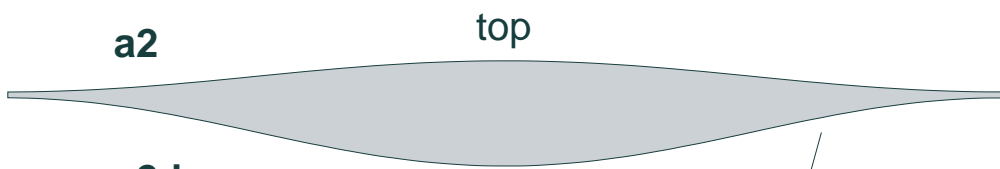
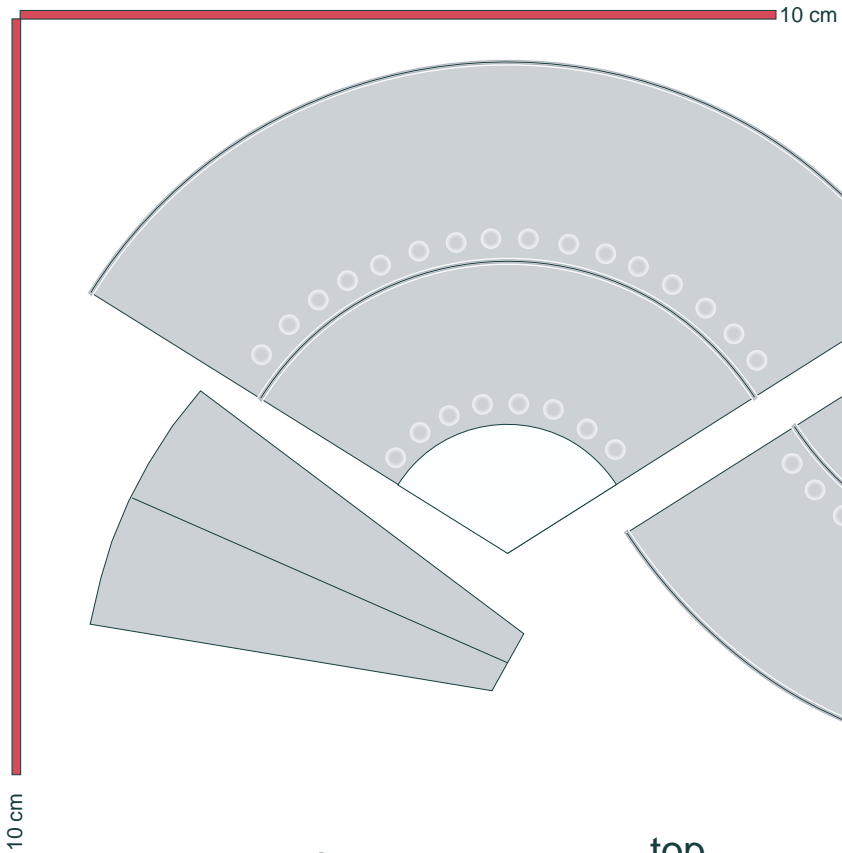

Top cones of busters A2 & A3

Glue part a2 onto a2-bs and immediately (before glue dry up) roll as semitubes. Take it by hard cylinder on soft (porous) surface from back side. Then glue a2 as a tube. Cut tothing only on dry one.

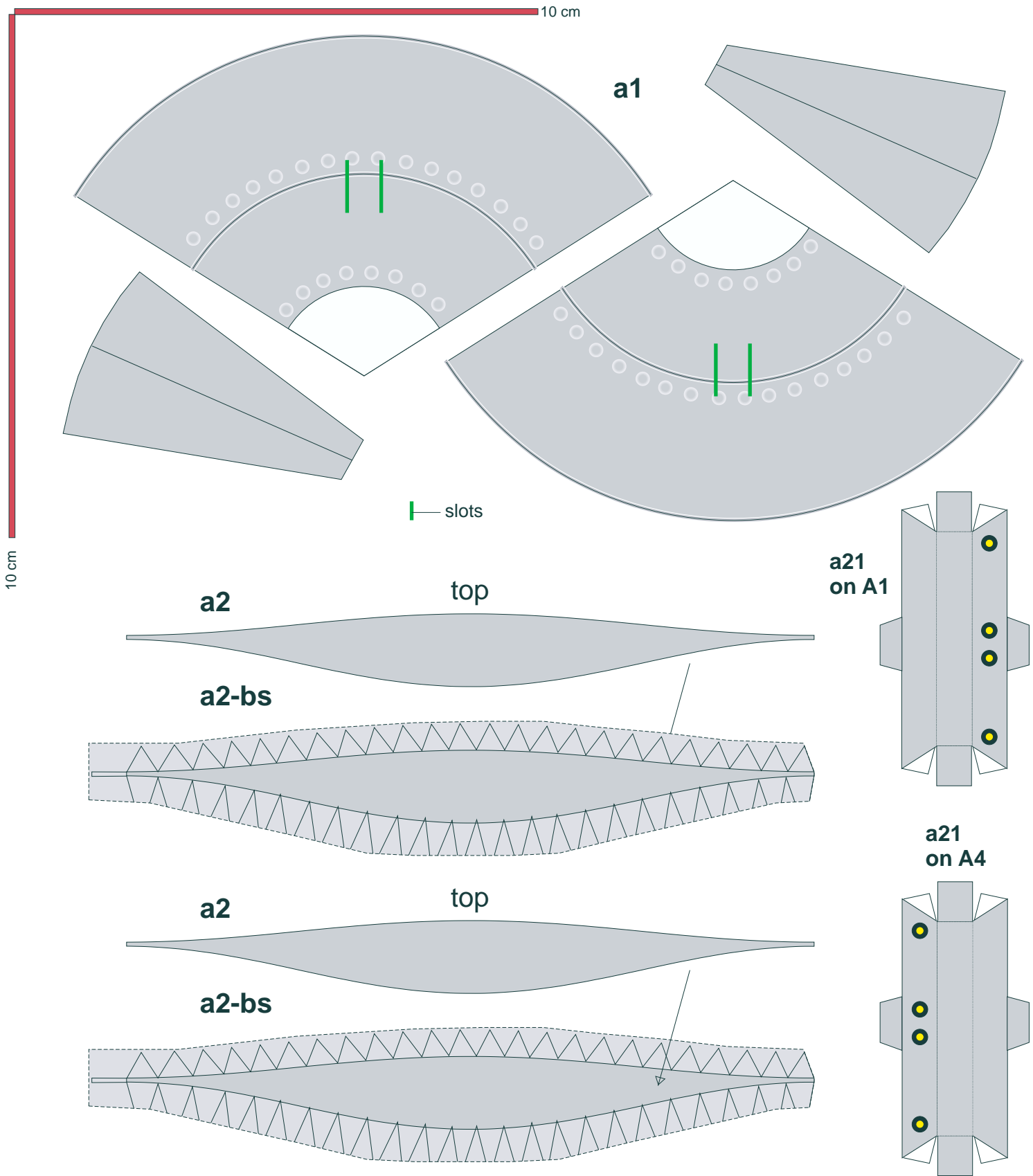

Top cones of busters A1 & A4

Glue part a2 onto a2-bs and immediately (before glue dry up) roll as semitubes. Take it by hard cylinder on soft (porous) surface from back side. Then glue a2 as a tube. Cut tothing only on dry one.

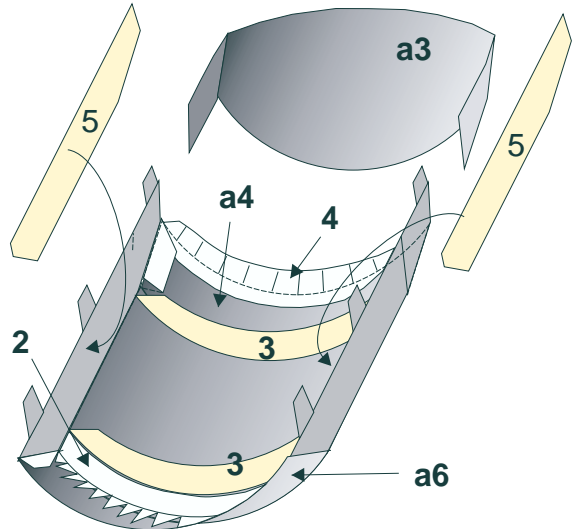
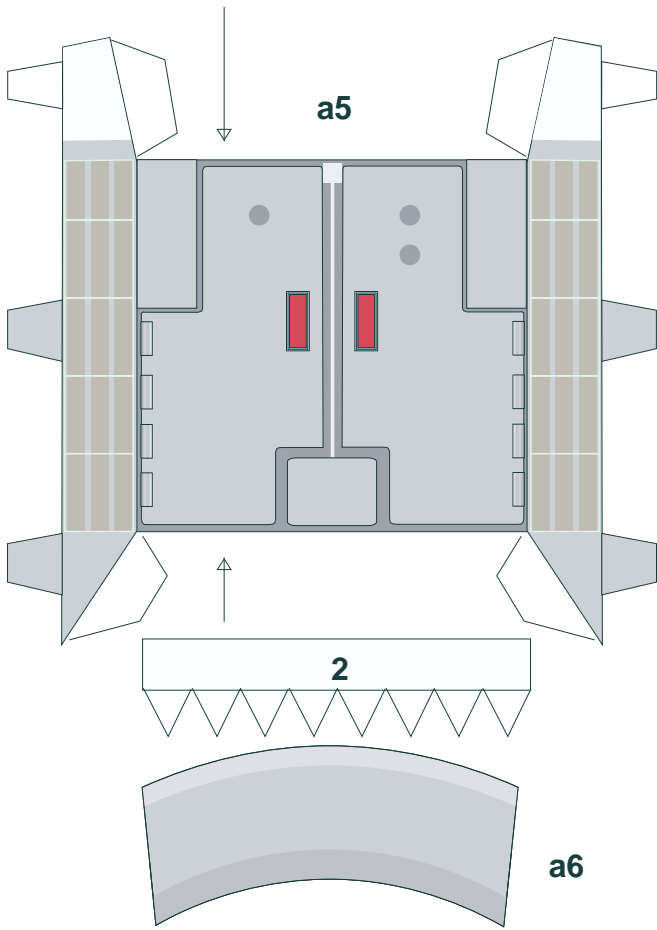
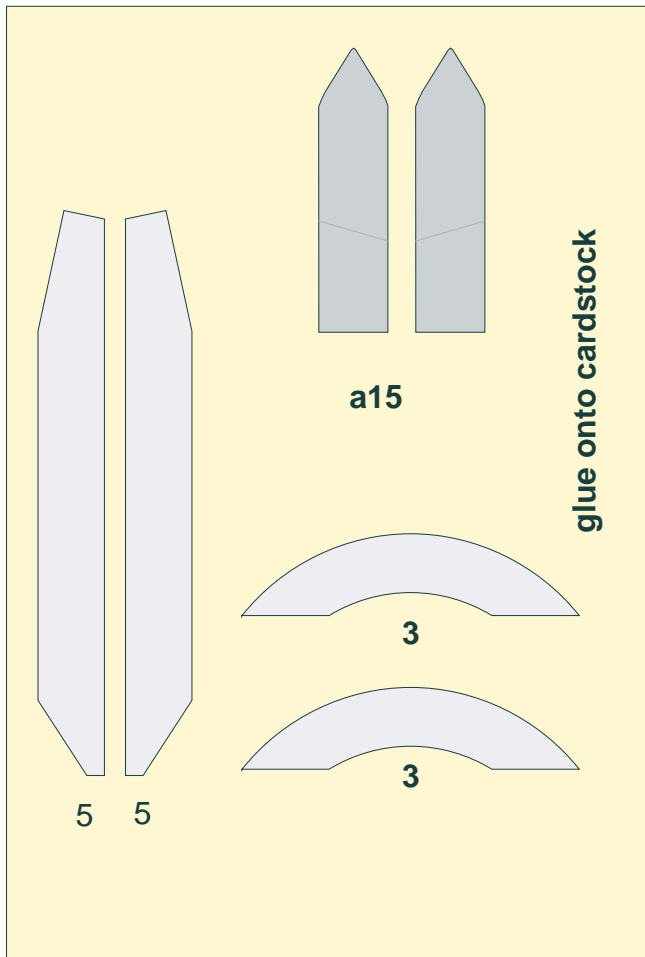
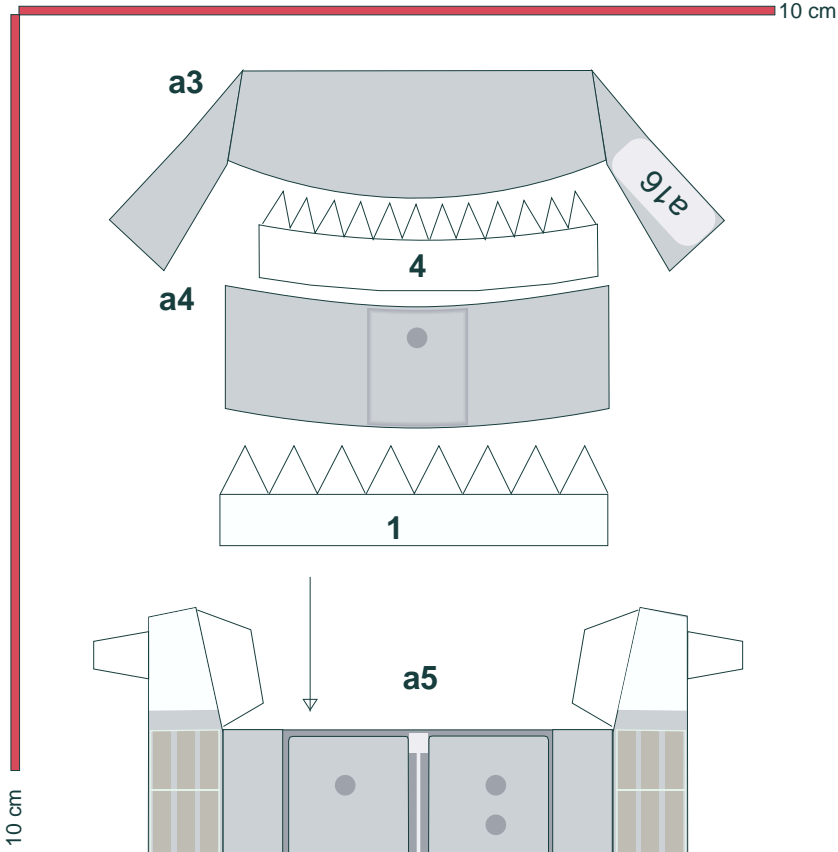

assembling of top part of saving system

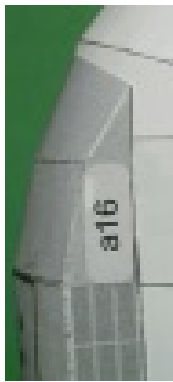

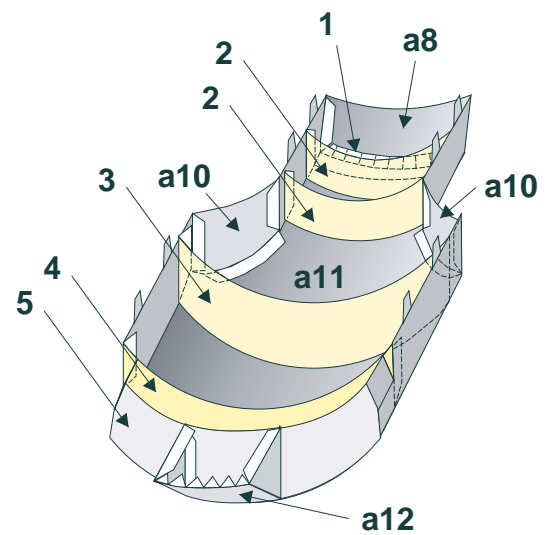
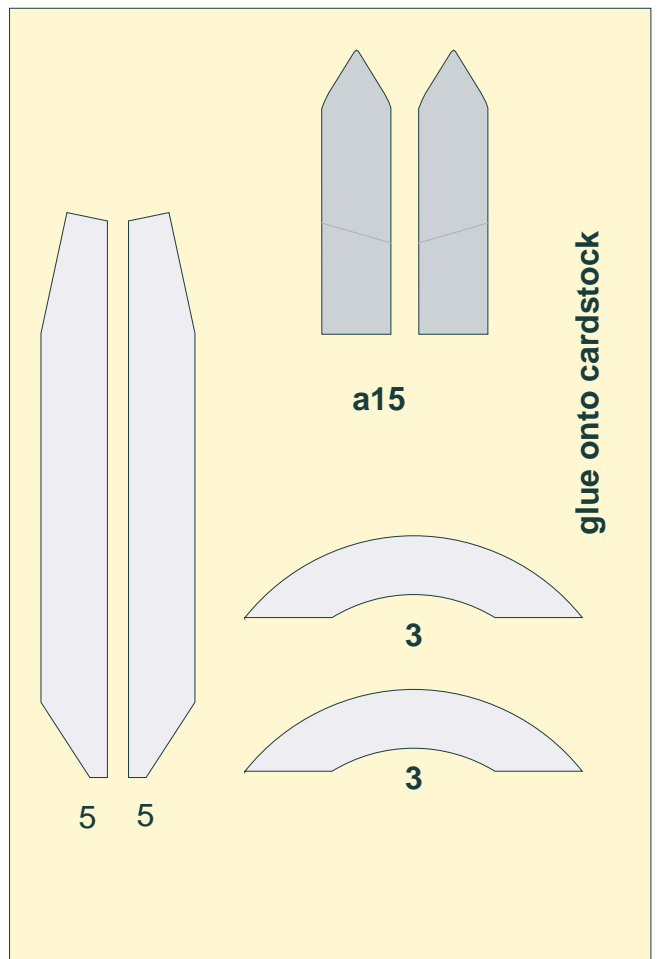
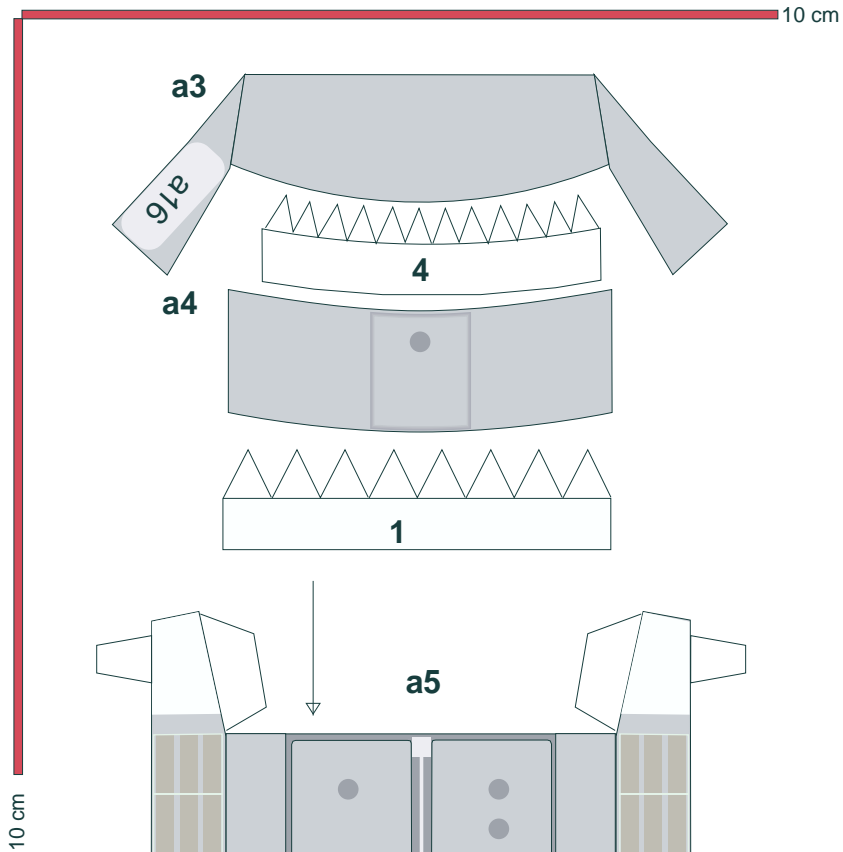

assembling of bottom part of saving system (see p.23)

10 cm

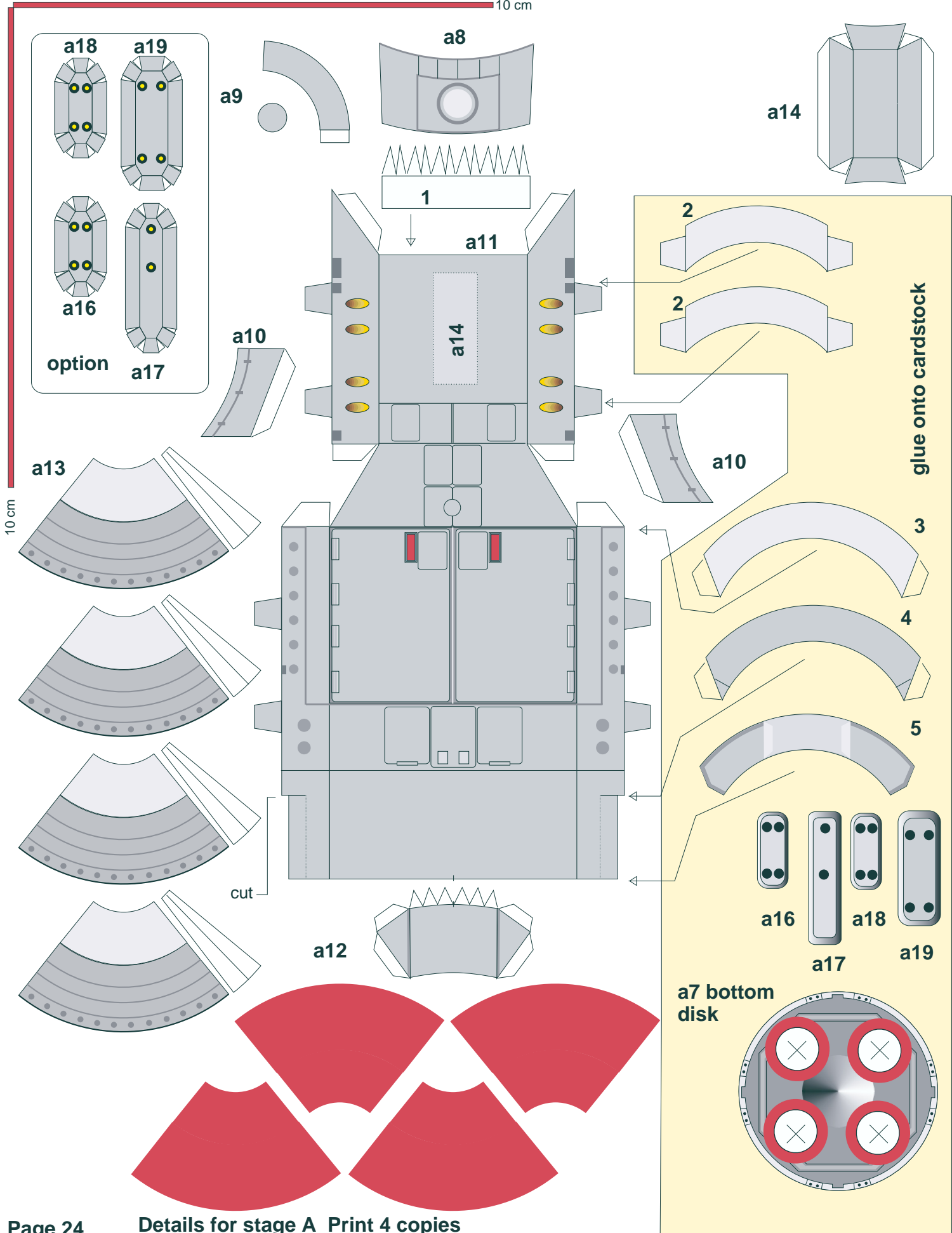

assembling A to B

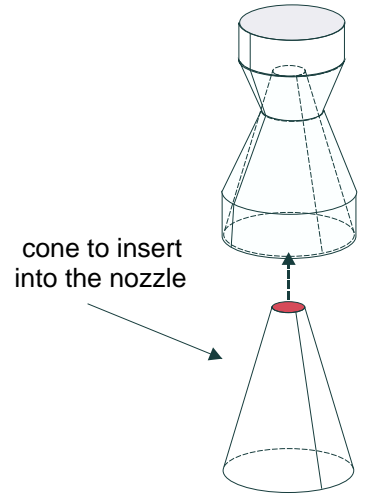
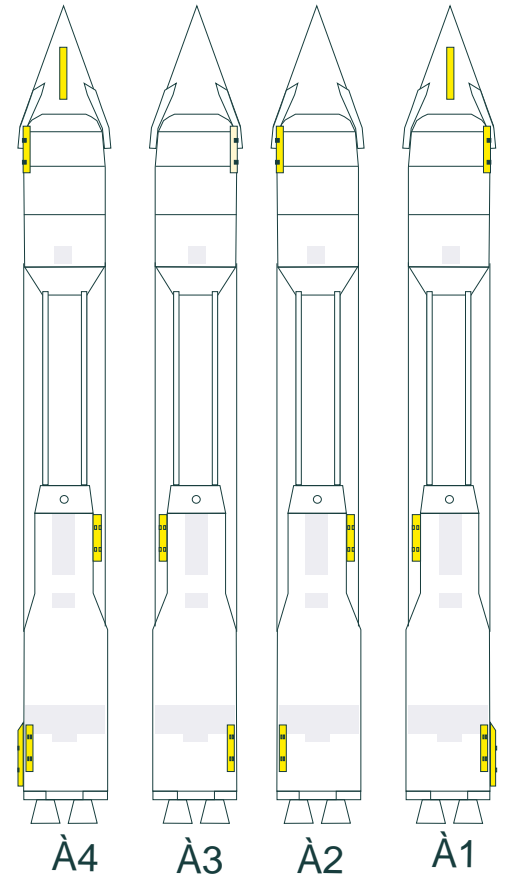
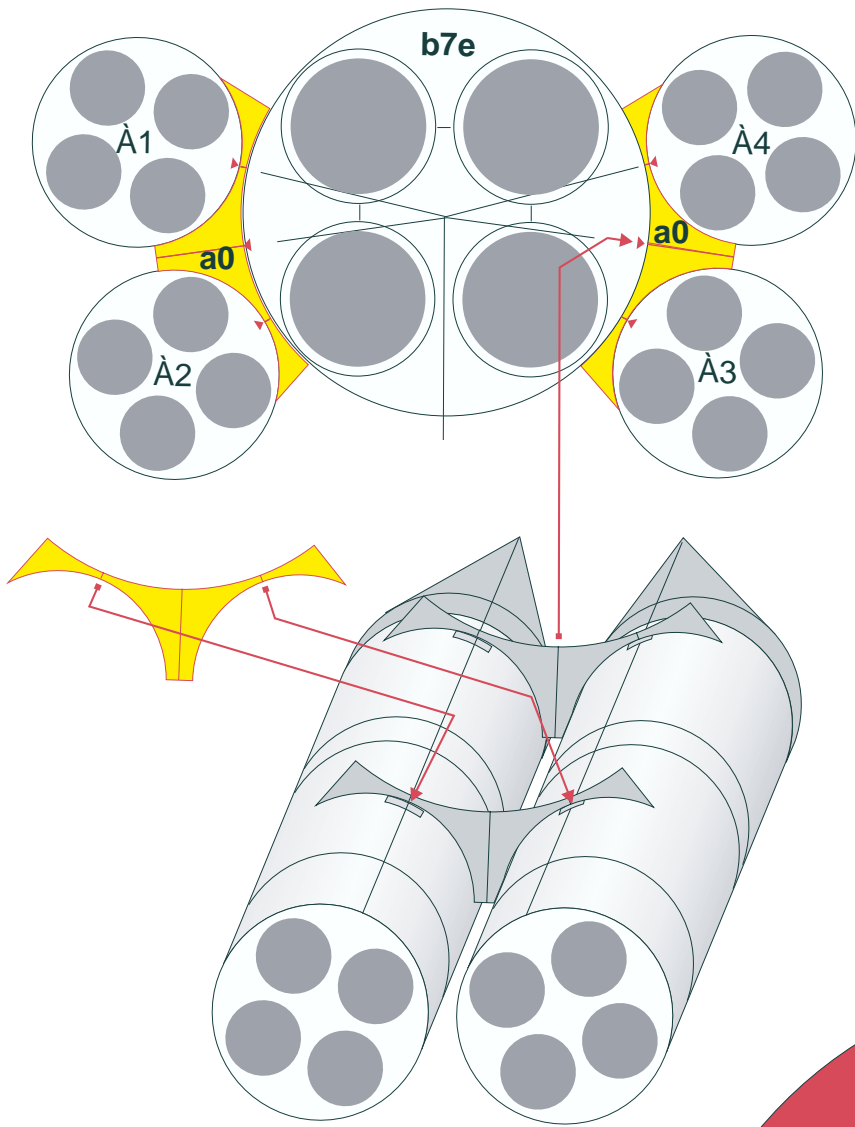

Glue parts a0 to A using markers "a0" on A, then glue pairs of blocks A on B, using markers "a0" on B. Ends of the nozzles of all blocks - in common plane.

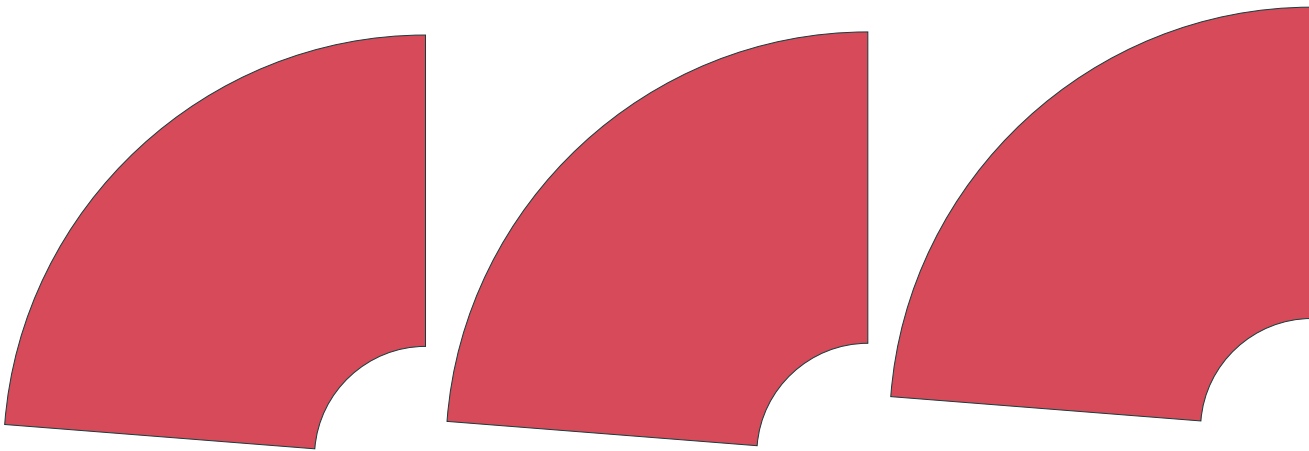

steps of assembling parts of body stage A

assembling parts of flyback system stage A

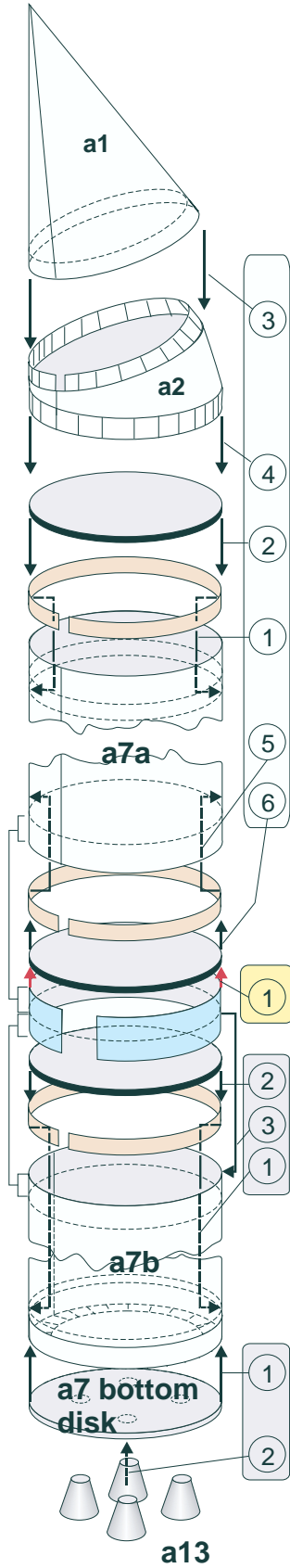

last step of assembling body of stage A

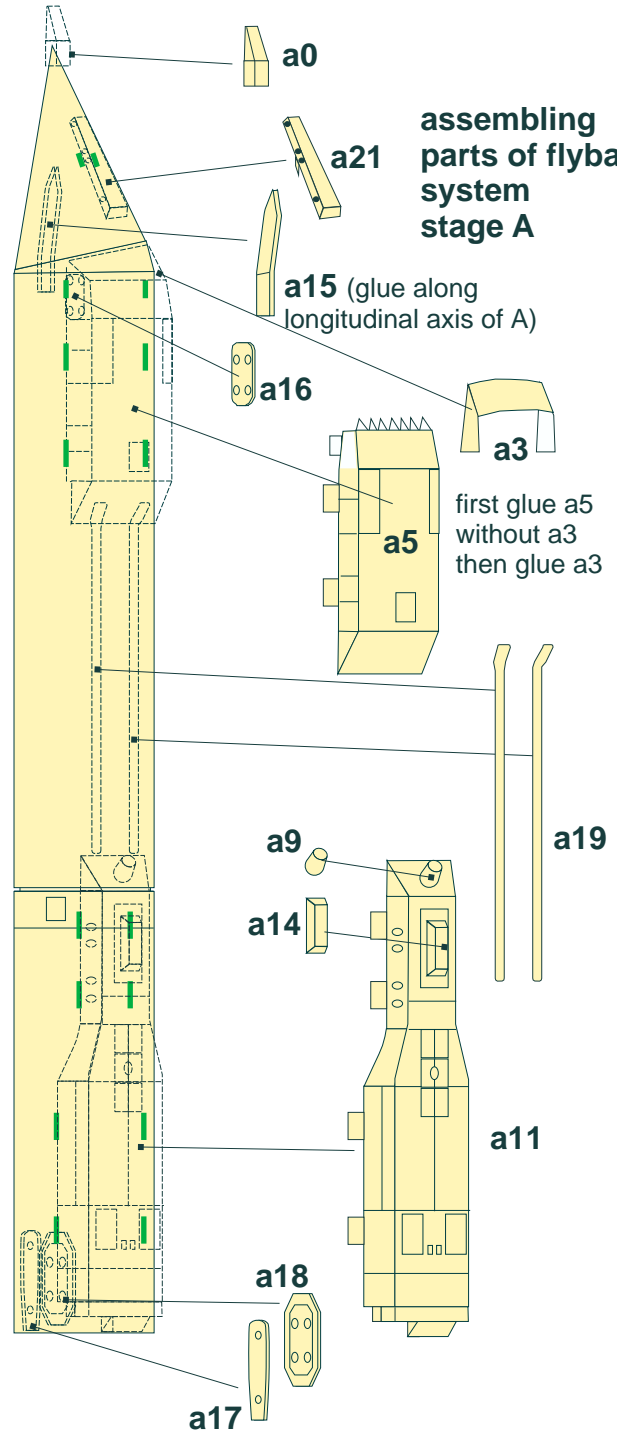

assembling supports for payload on body of stage B

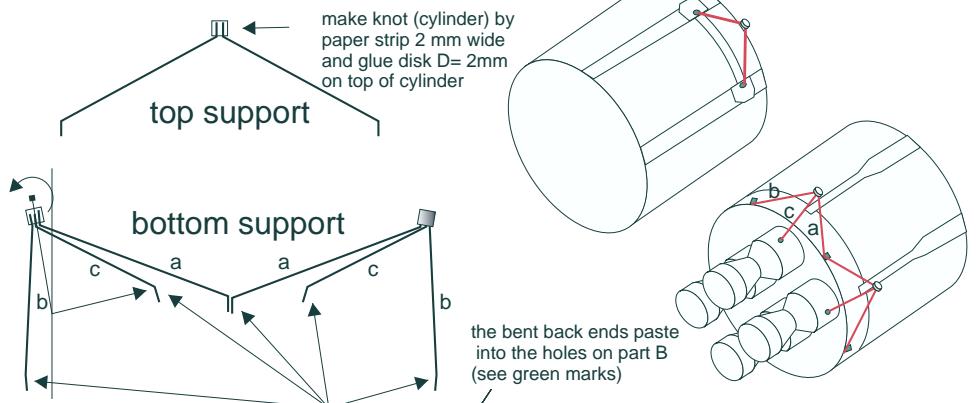

Template for assembling of Stages A & B

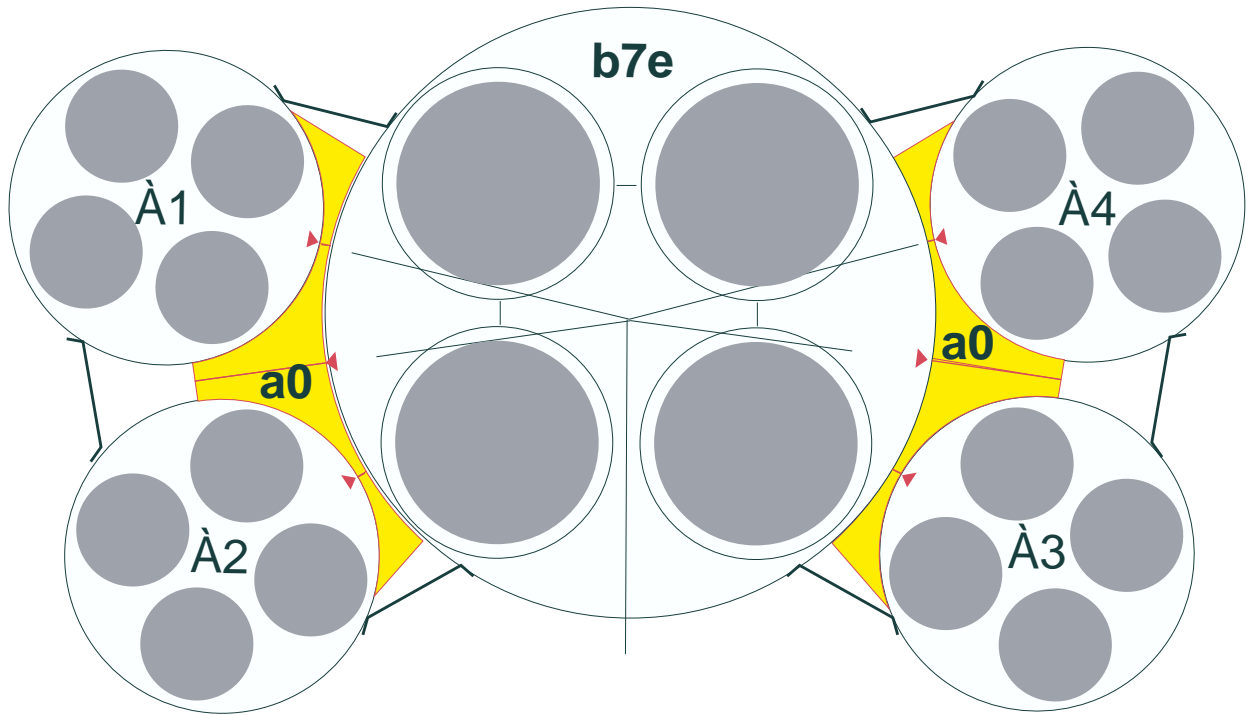

10 cm