

# Mars Science Laboratory – Curiosity Rover

1:24 scale

The Mars Science Laboratory (MSL) landed on Mars in August 2012 and will operate for at least one Mars year (approximately two Earth years). MSL is part of NASA's Mars Exploration Program, a long-term effort of robotic exploration of the red planet. The Curiosity rover will assess whether Mars ever was, or is still today, an environment able to support microbial life. In other words, its mission is to determine the planet's "habitability."

To find out, the rover carries the biggest, most advanced suite of instruments for scientific studies ever sent to the Martian surface. The rover will analyze dozens of samples scooped from the soil and drilled from rocks. The rover's onboard laboratory will study rocks, soils, and the local geologic setting in order to detect chemical building blocks of life (e.g., forms of carbon) on Mars and will assess what the Martian environment was like in the past.

MSL relies on new technological innovations, especially for landing. The spacecraft made a guided reentry, slowed and descended on a parachute and then released a rocket powered "skycrane" which slowed to a hover and lowered the rover to the surface on a tether. This innovative approach was needed to allow the rover, the heaviest ever sent to another planet, to safely land on rough terrain while avoiding excessive backblast from the landing rockets.

The rover will be able to roll over obstacles up to 75 centimeters (29 inches) high and travel up to 90 meters (295 feet) per hour. The rover carries a radioisotope power system that generates electricity from the heat of plutonium's radioactive decay. This power source gives the mission an operating lifespan on Mars' surface of a full Martian year (687 Earth days) or more, provides greater mobility and flexibility than solar panel, allows a bigger science payload, and does not rely on varying seasonal sunshine for power.

To build the model you will need to print the parts onto cardstock. You'll need scissors/craft knife, glue, a drinking straw, and some pins. Making the model takes 4-6 hours to complete.

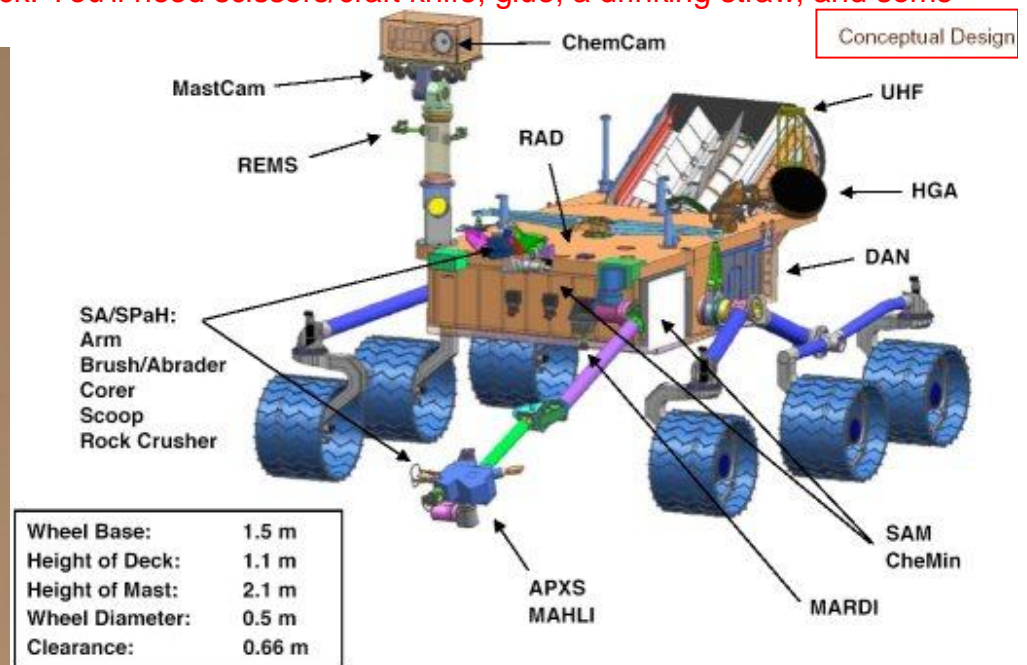

# Mars Science Laboratory – Curiosity Rover

1:24 scale

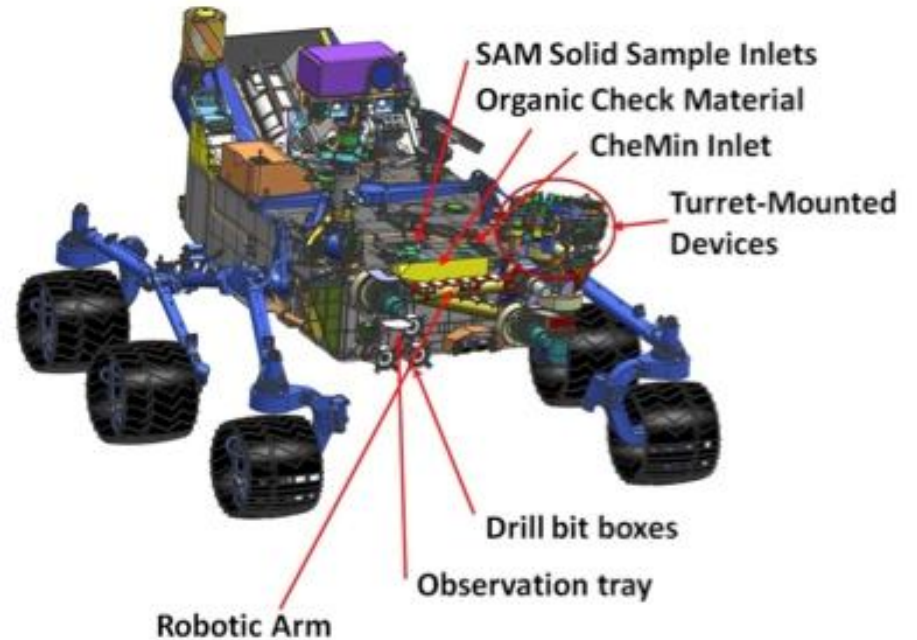
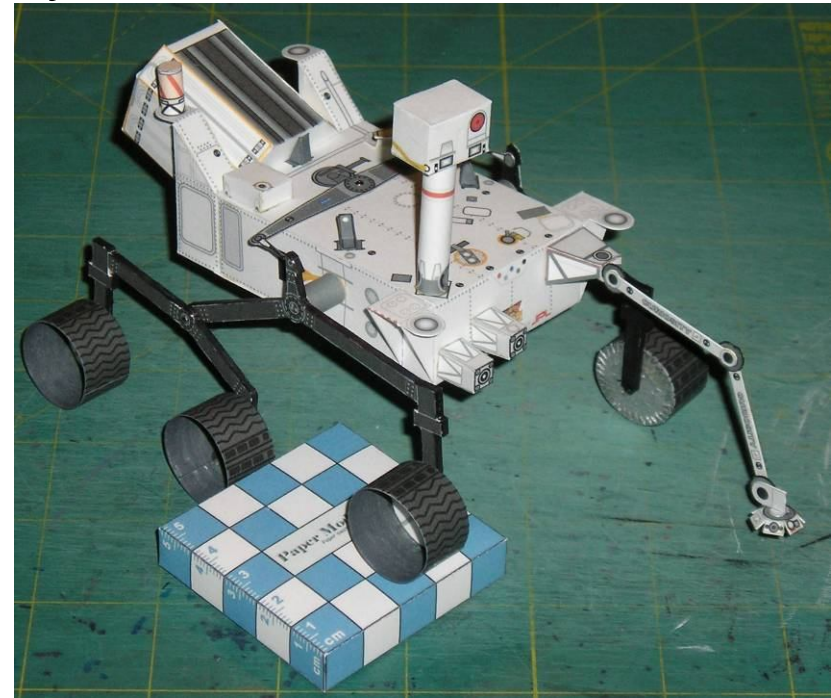



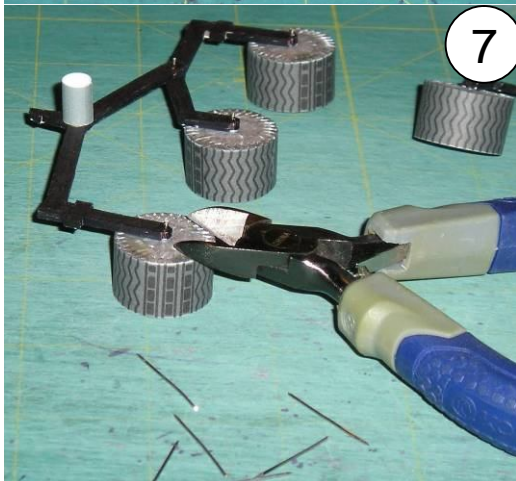
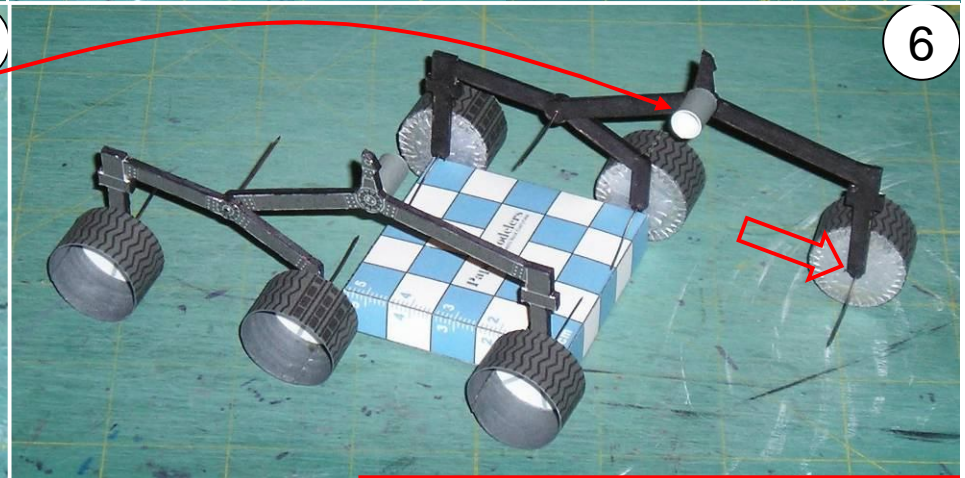
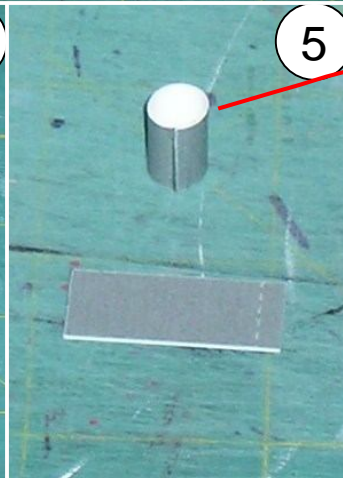
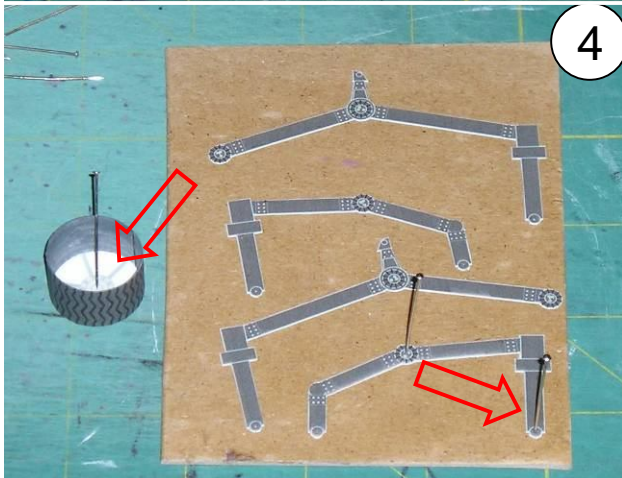
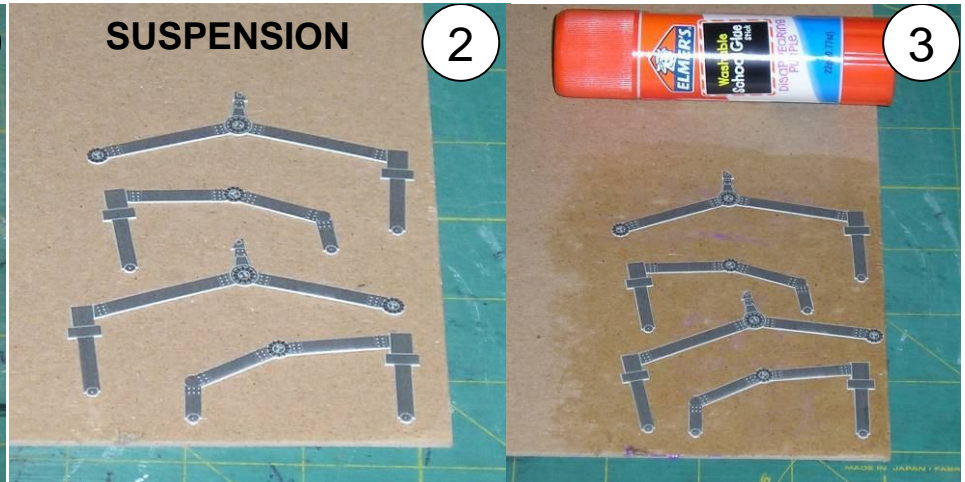
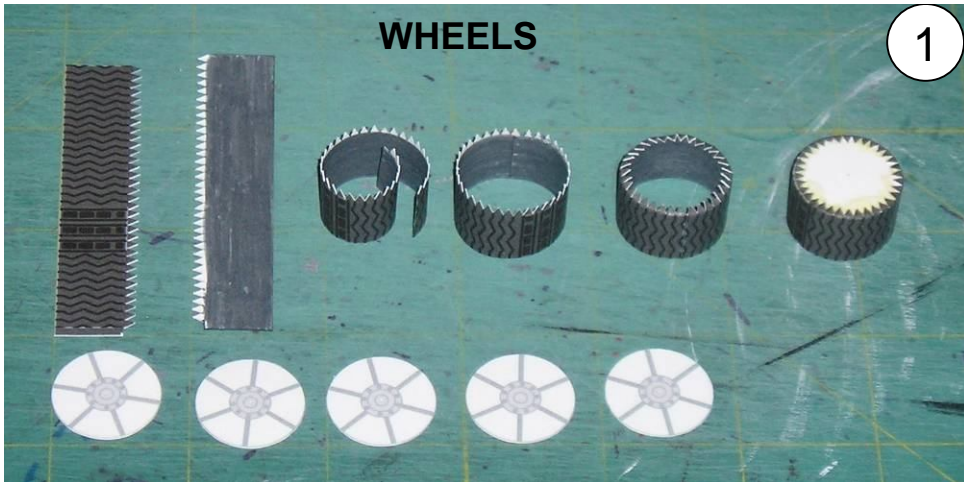

**MAIN AXLE-DRINKING STRAW**



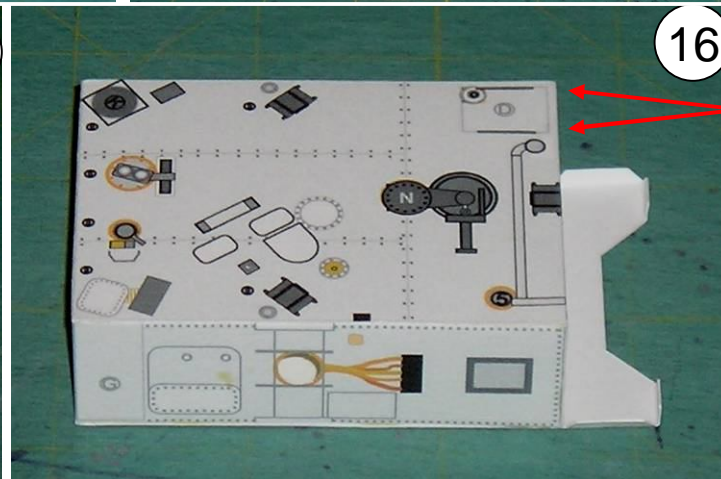
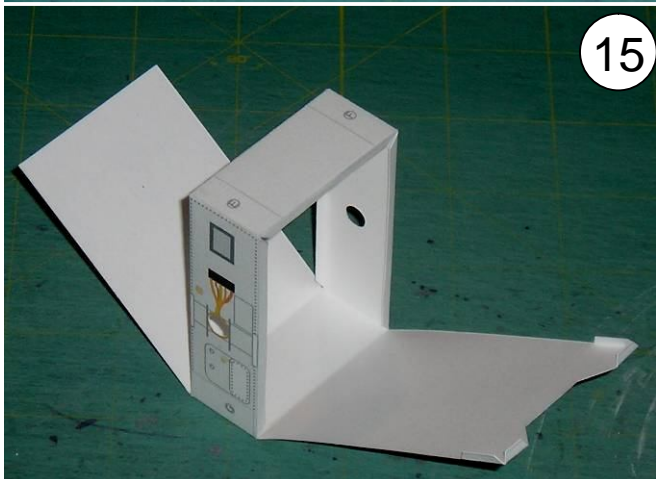
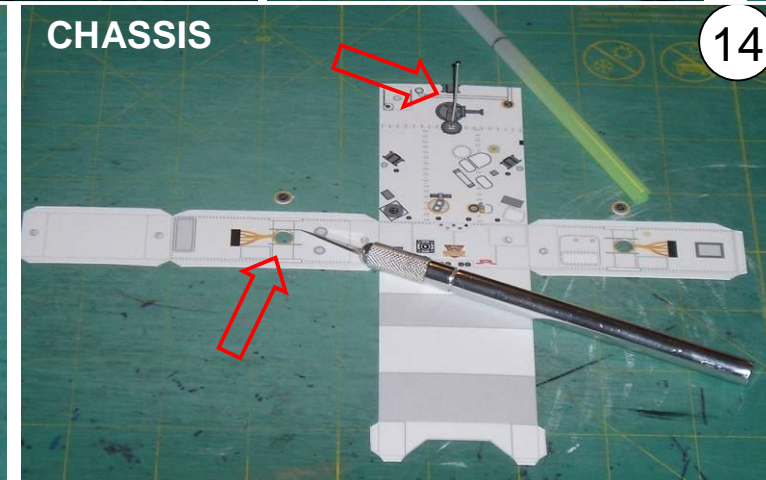
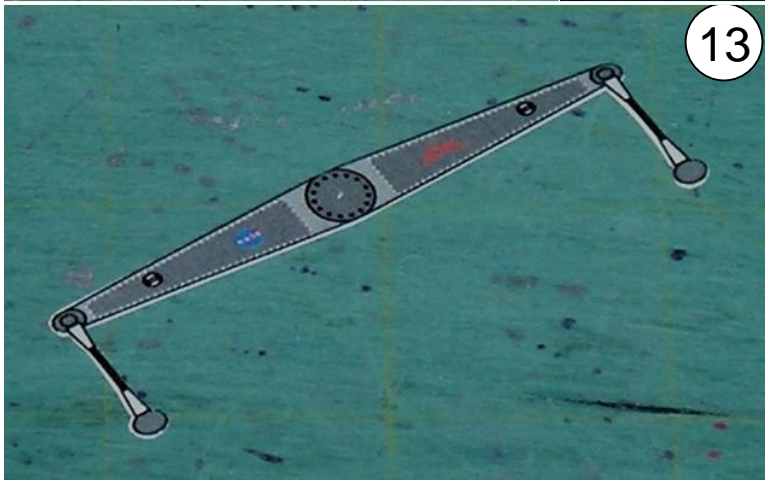
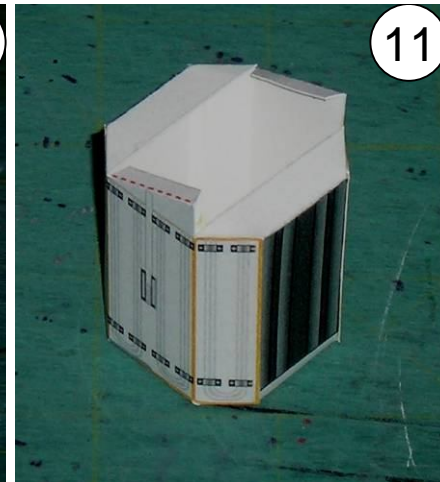
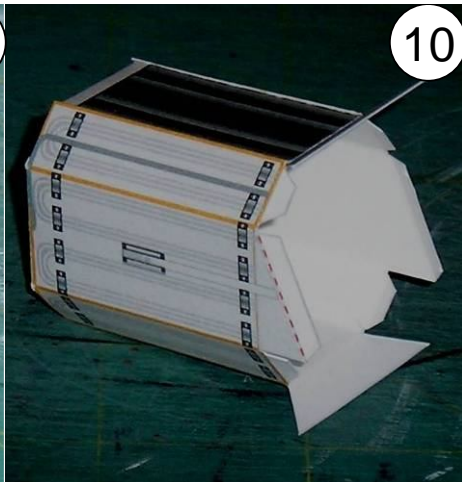
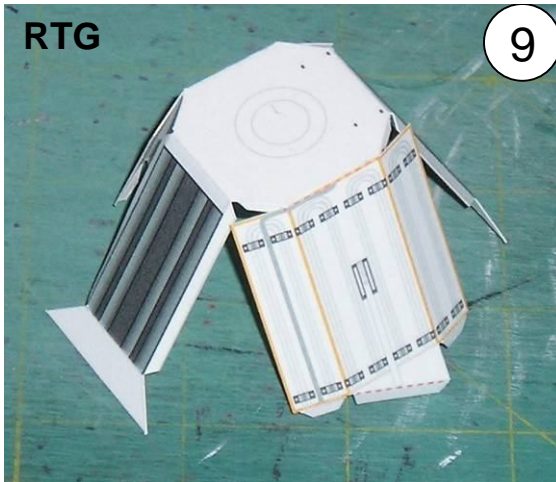

Cut slits for equipment box mounting tabs (21) (22)



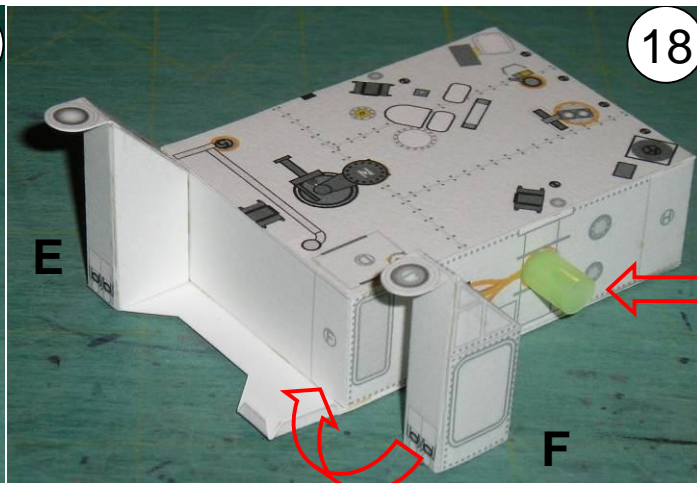
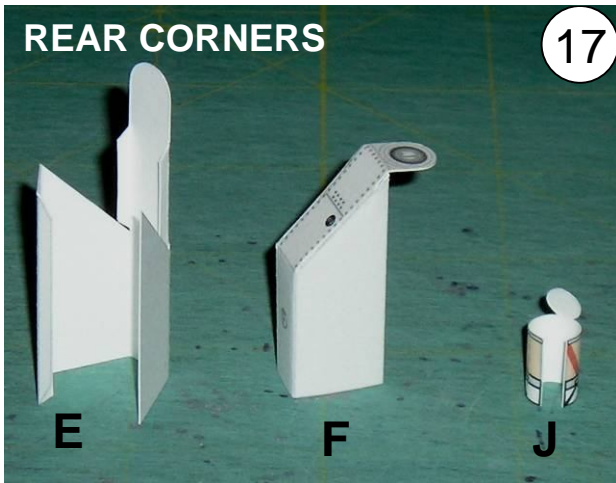

**INSERT STRAW TO SUPPORT SUSPENSION**

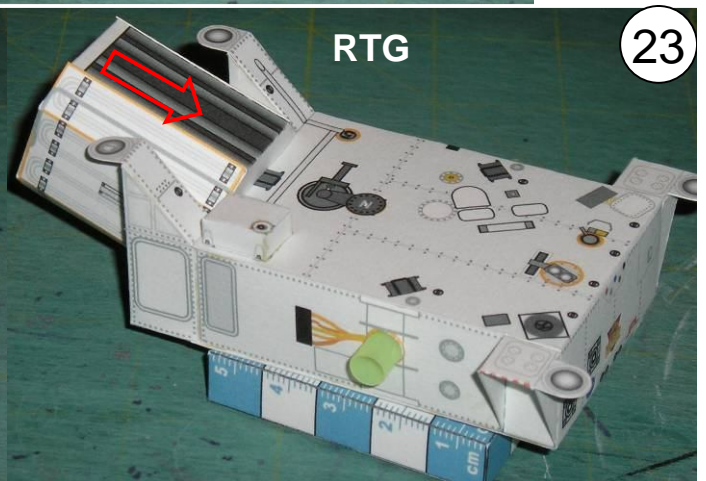
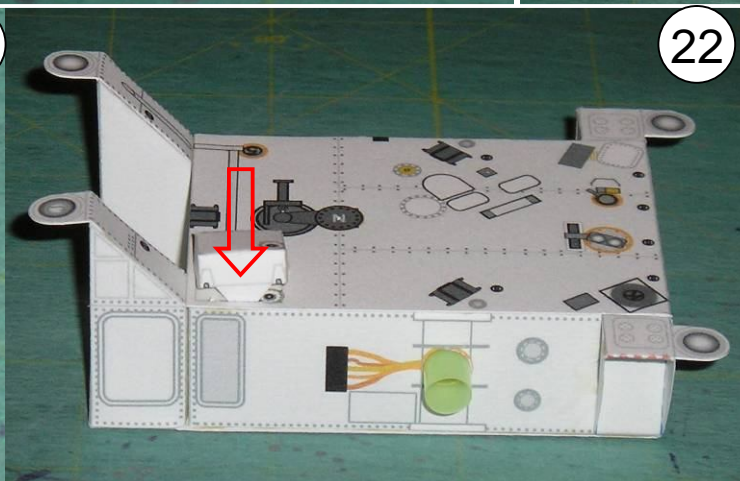
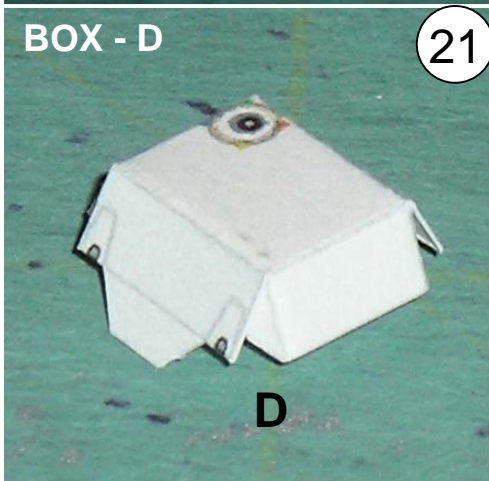
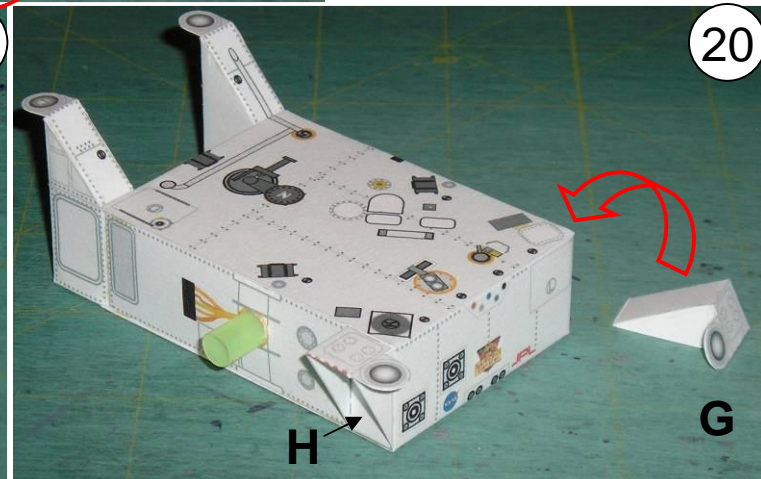
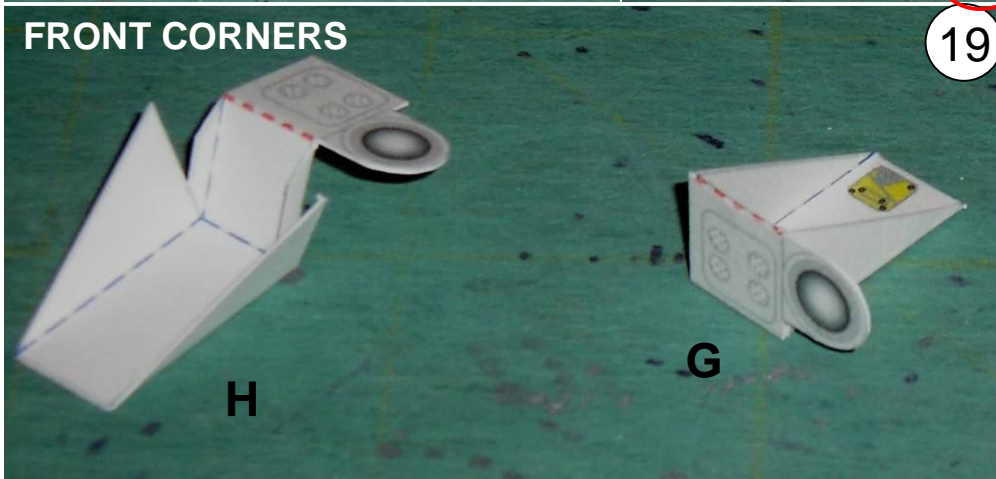



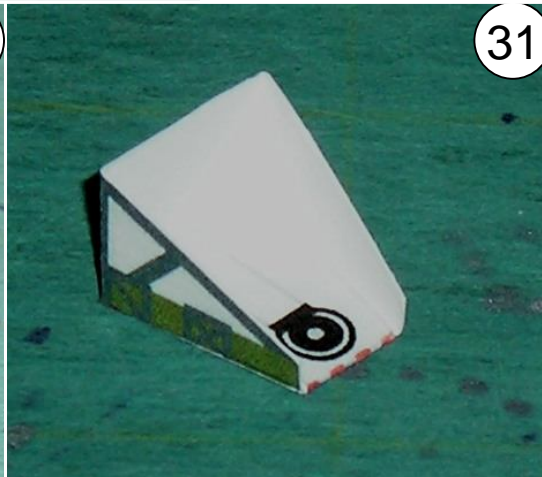
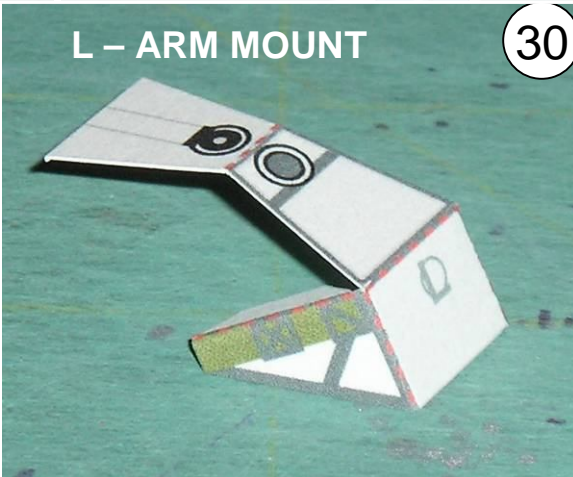
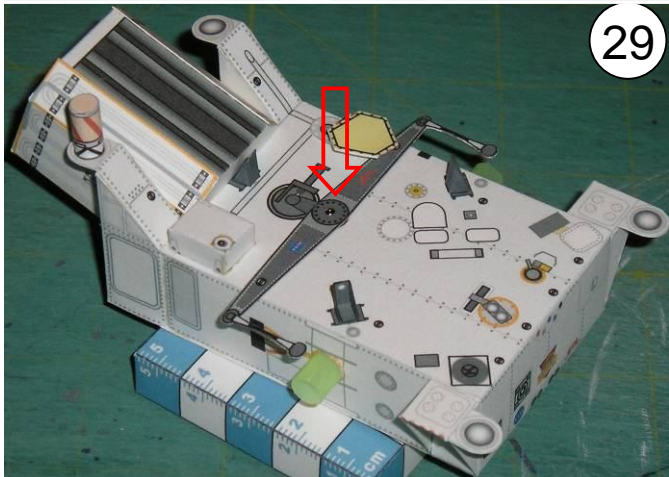
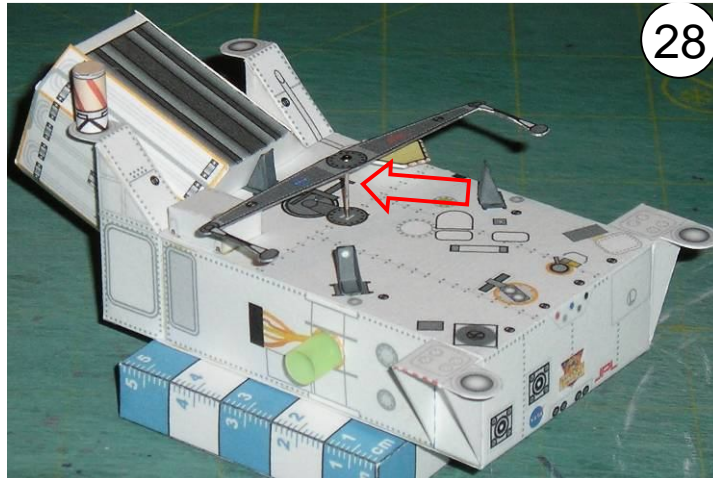
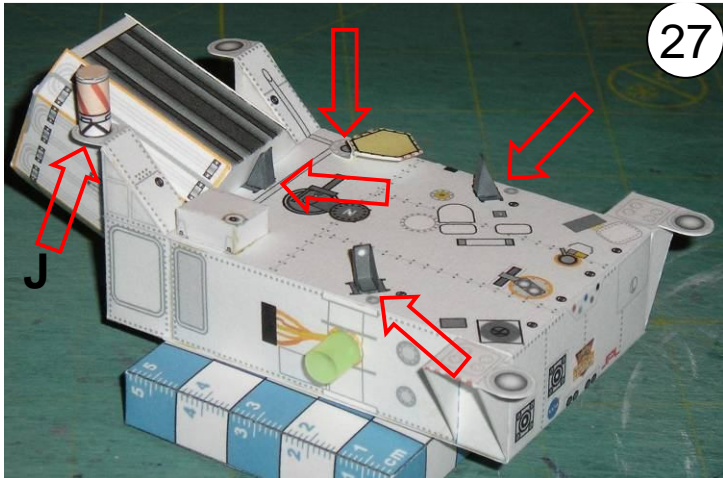
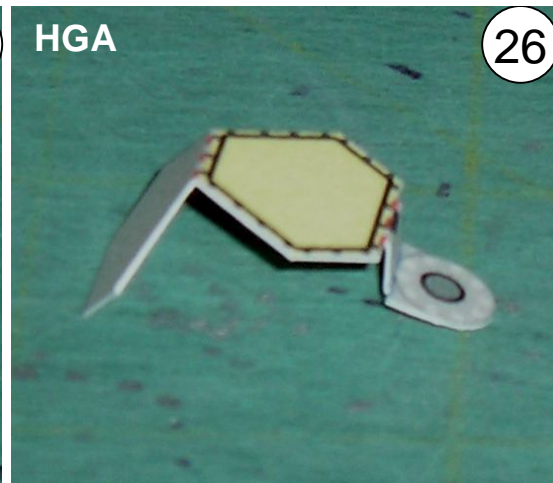
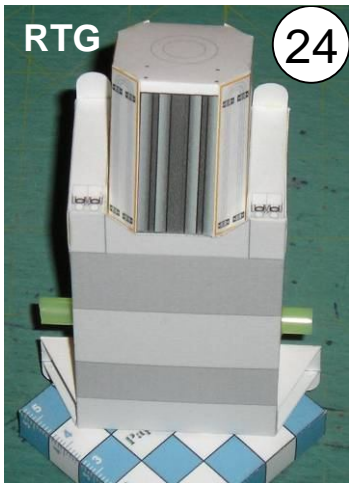



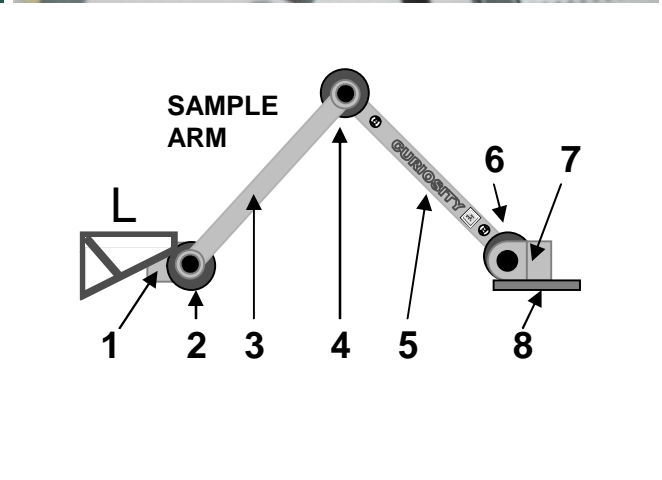
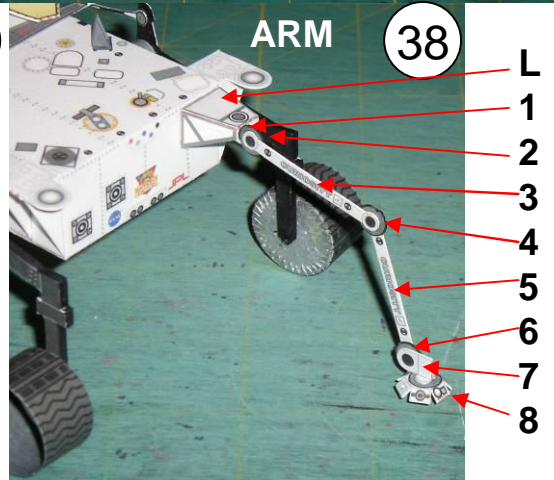
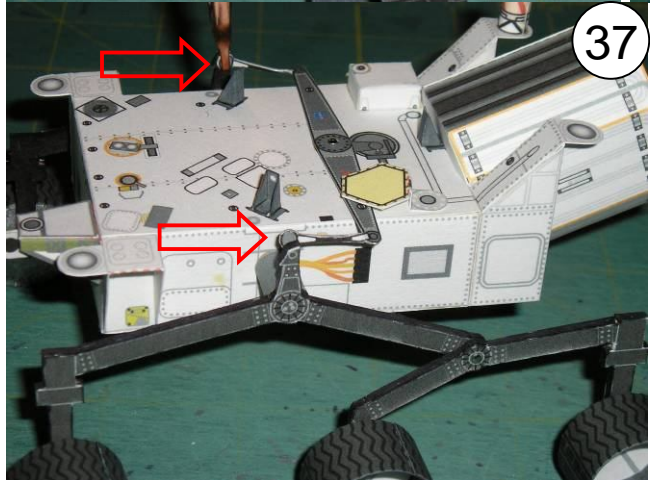
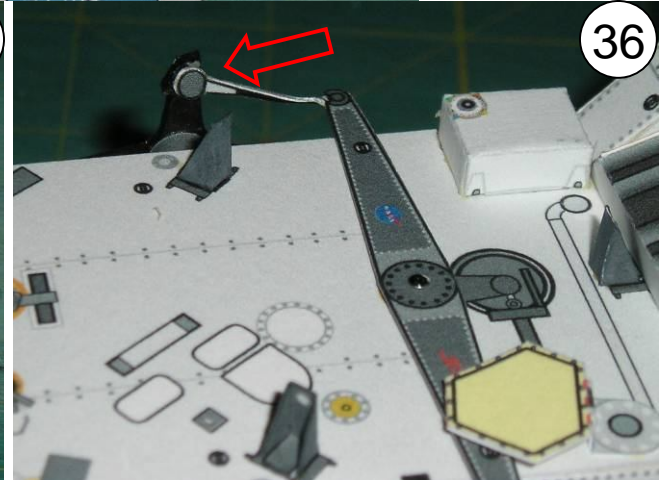
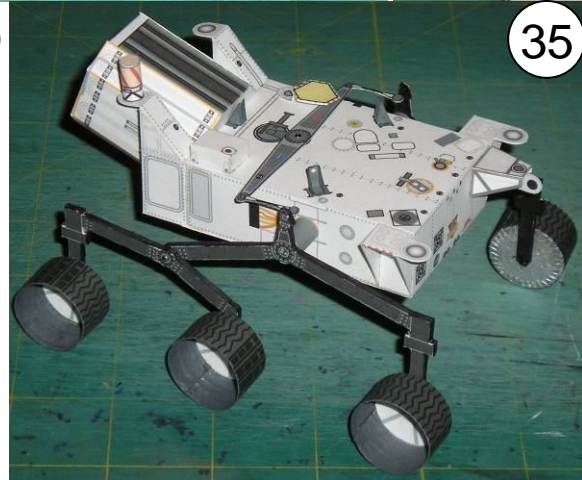
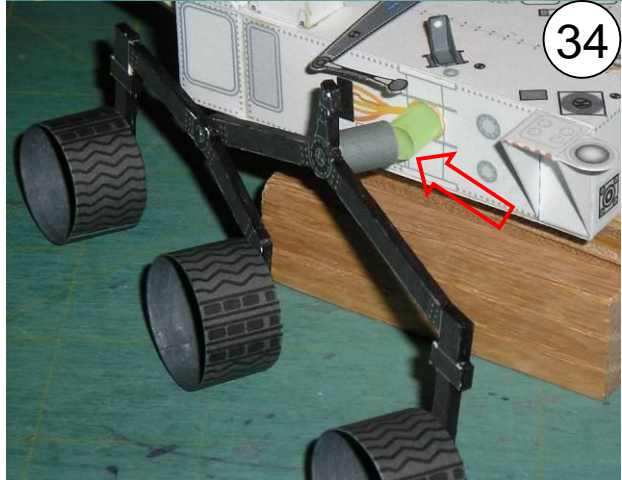
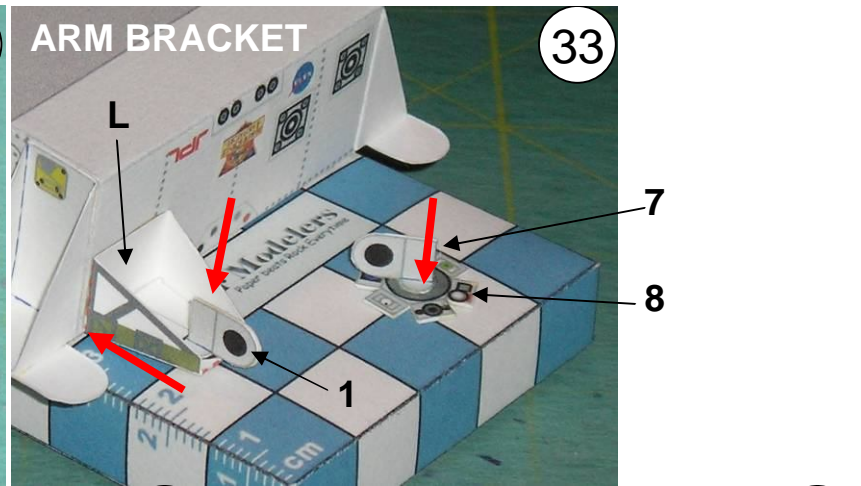
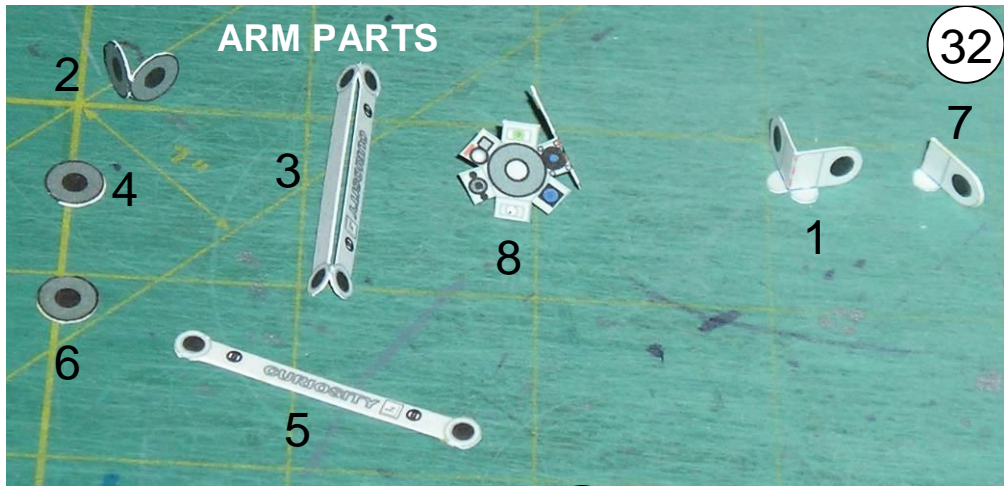



MASTCAM

39

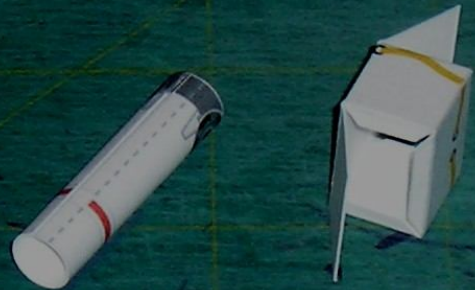

40



41

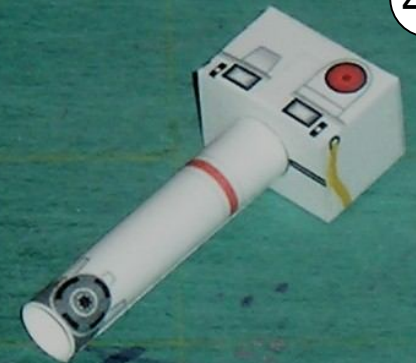

42

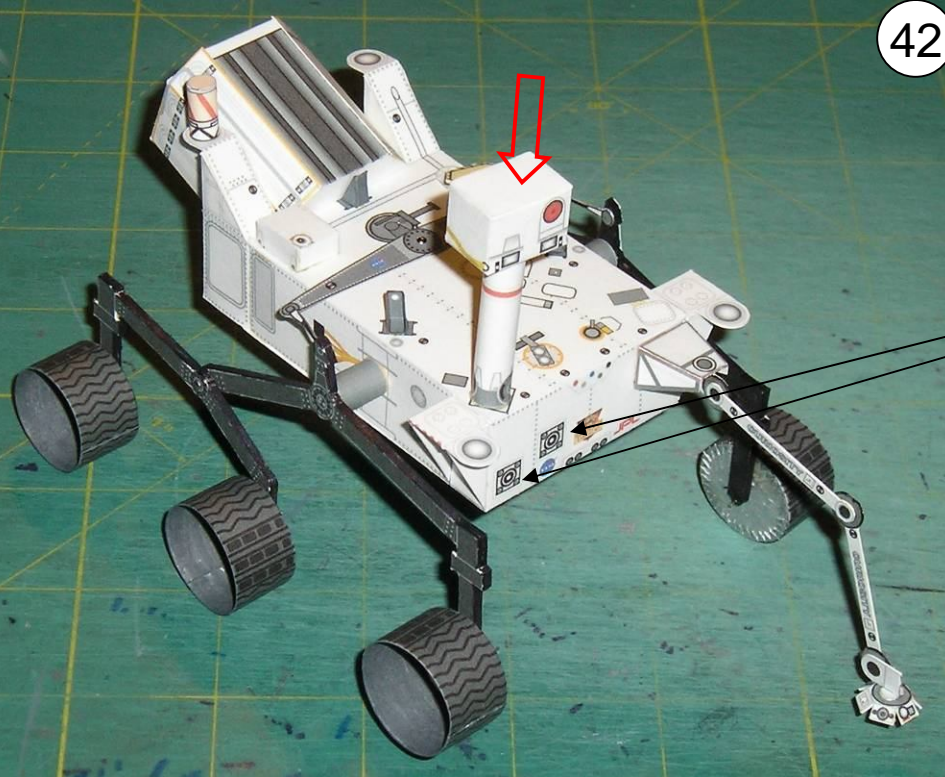

OPTIONAL DRILL BIT HOLDERS

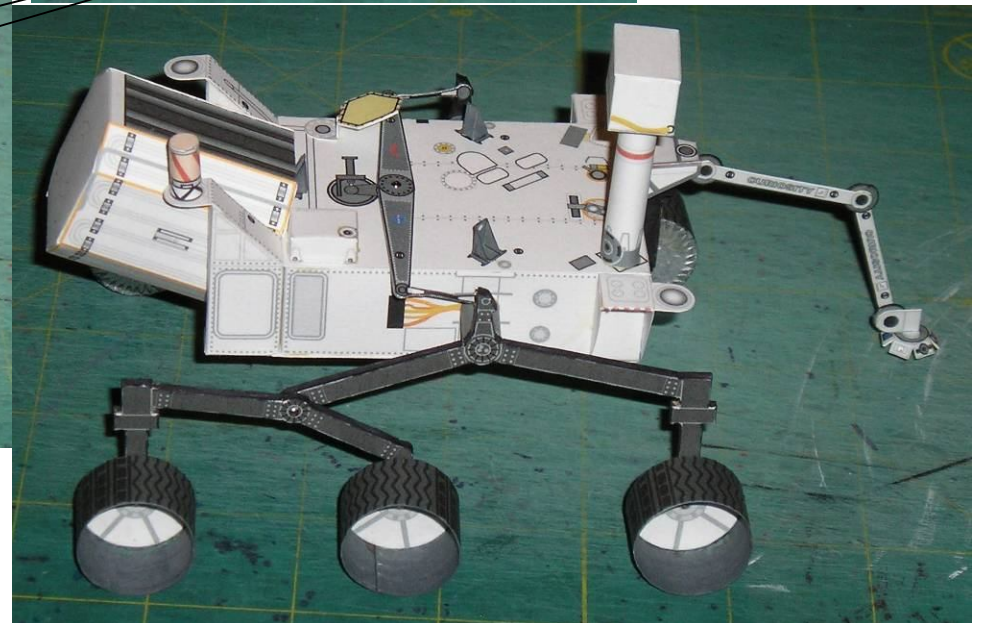



# MSL Curiosity Rover

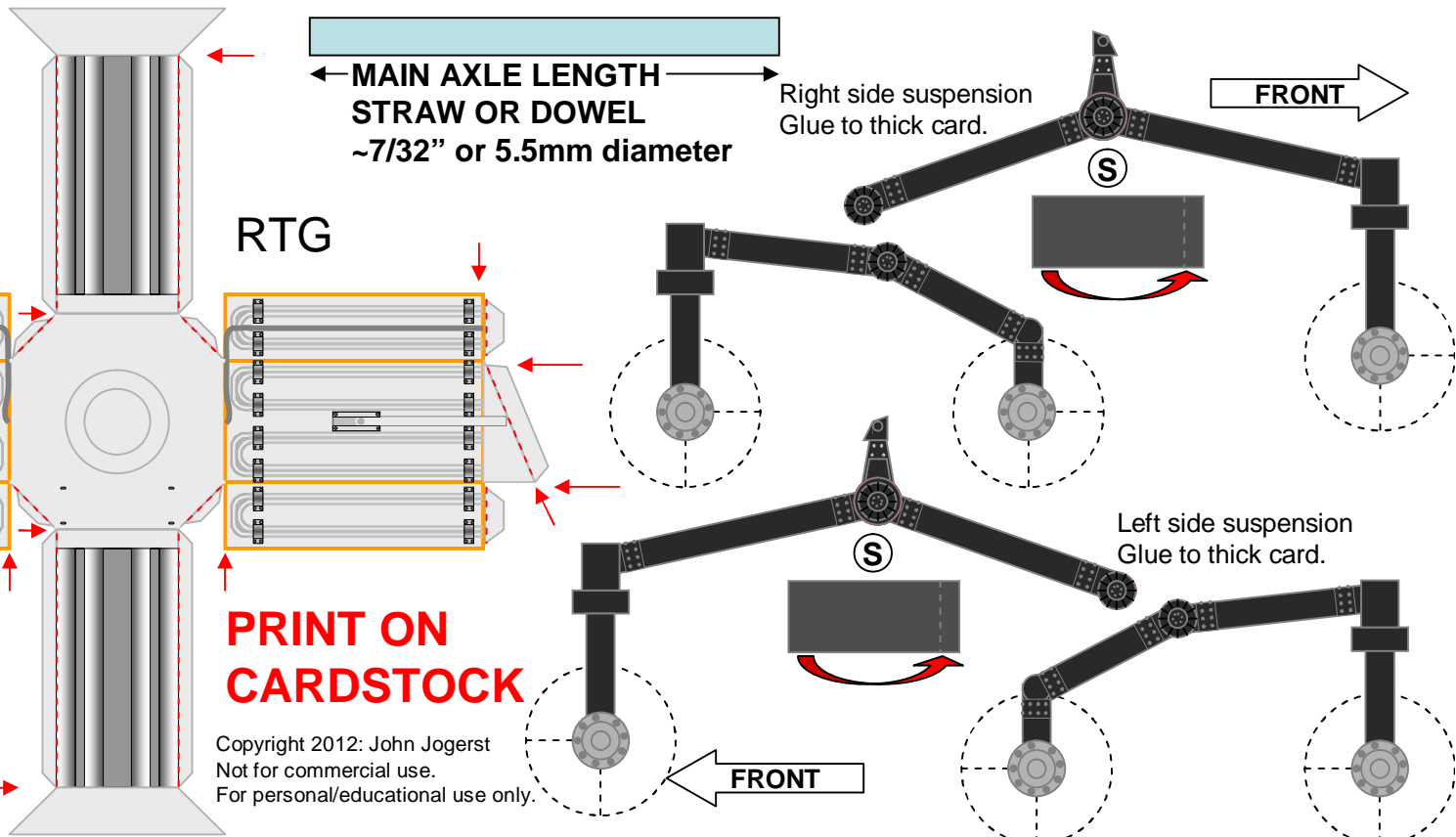
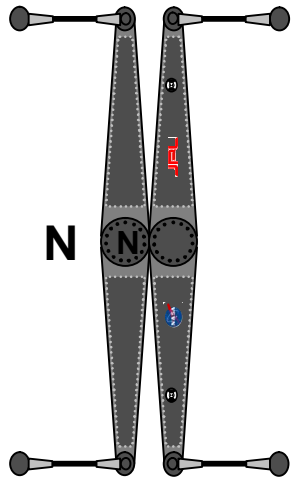
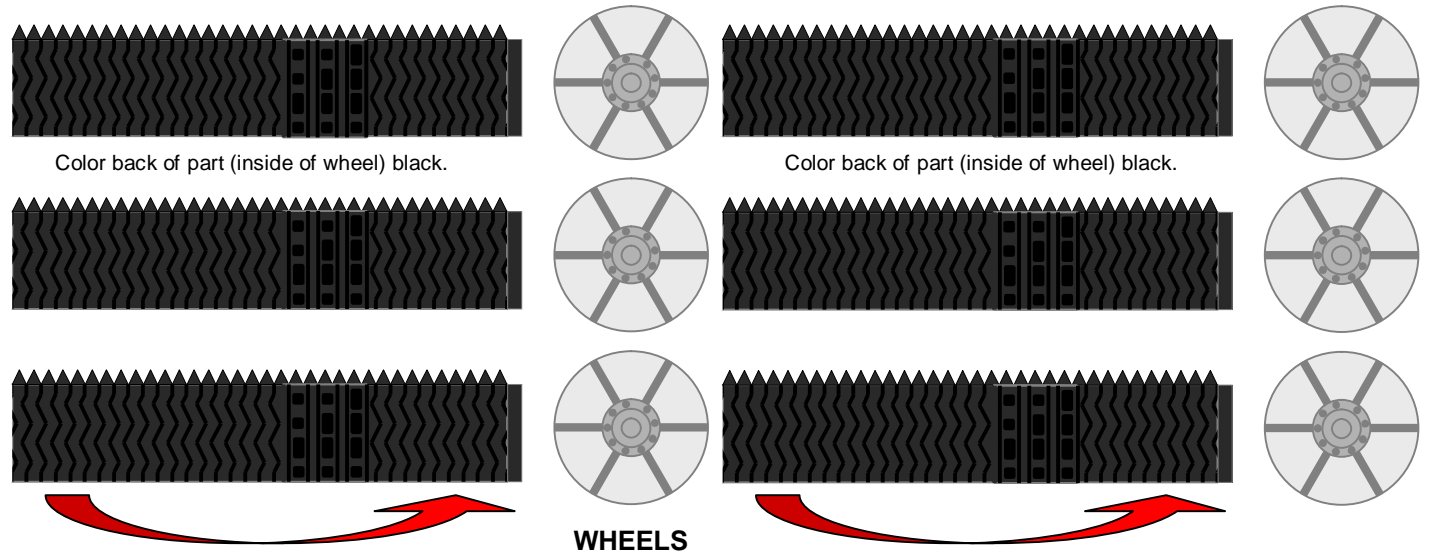
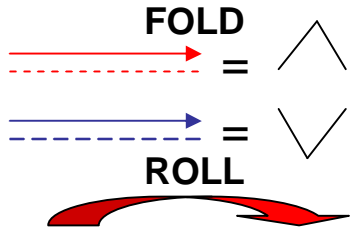

**MARS REGISTRATION**



# MSL Curiosity Rover

